

IEEE-std-287 Conformed

Precision Coaxial Connectors

3.5mm/3.5mm
DC - 26.5GHz



2.92mm/2.92mm
DC - 40GHz



2.4mm/2.4mm
DC - 50GHz



1.85mm/1.85mm
DC - 65GHz



1mm/1mm
DC - 110GHz



Adapters Within Series

3.5mm/2.4mm
DC - 26.5GHz



2.92mm/2.4mm
DC - 40GHz



2.92mm/1.85mm
DC - 40GHz



2.4mm/1.85mm
DC - 50GHz



1.85mm/1mm
DC - 67GHz



Adapters Between Series

1.85mm/1.85mm
DC - 65GHz



2.92mm/2.92mm
DC - 40GHz



1.85mm/1.85mm
DC - 65GHz



Panel Adapters

Front Panel Adapter

1.85mm
DC - 65GHz



2.92mm
DC - 40GHz



1mm
DC - 110GHz

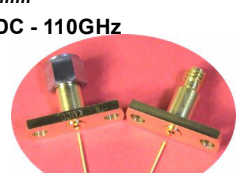

Launchers & Glass Beads

1.85mm/1.85mm
DC - 65GHz



2.92mm/2.92mm
DC - 40GHz



1mm for DC - 110GHz, 1.85mm for DC - 60GHz and DC - 65GHz, 2.92mm for DC - 40GHz. Also available between-assemblies



Re-Formable Semirigid Cable Assemblies

FOE2007

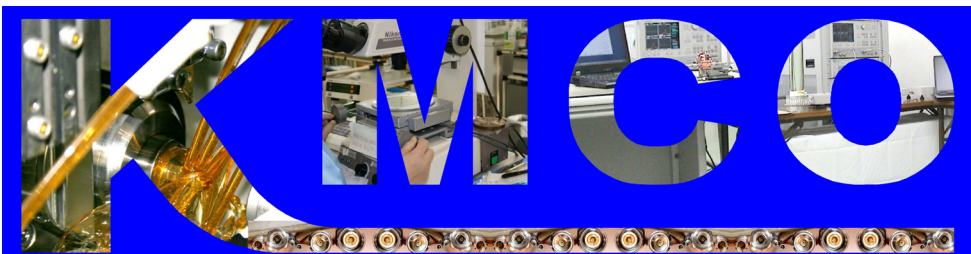

KMCO 同軸、光、コネクタ製造
株式会社 川島製作所



〒214-0031
川崎市多摩区東生田 1-3-5
営業 電話 044-911-7052
FAX 044-911-2561
技術 電話 044-911-7073
FAX 044-911-9621

1mm/1mm

DC - 110GHz, Coaxial Adapters, In-Series

DESCRIPTION

These "KPC100MF,FF and MM" coaxial adapters that small size, low SWR and low loss, are designed for the ultra-broadband (up to sub-millimeter wave) measurement, instrument and system use.

SPECIFICATIONS:

Electrical:

Frequency Range DC - 110 GHz
 Return Loss Better than 18dB(*),15dB(**)
 Insertion Loss <0.45dB
 Electrical Length 11.6 mm [Nominal]
 Temperature Range -55 to +125

Mechanical:

Body and Outer Conductors:
 -Gold Plated Stainless steel
 Inner Conductors:
 -Gold Plated Beryllium Copper and Brass
 Coupling Torque 45 N-cm(Nominal)
 Connect/Disconnect Life >500 Cycles [Predicted]



Typical Performance

TYPE: KPC100MF 1mm Male/1mm Female

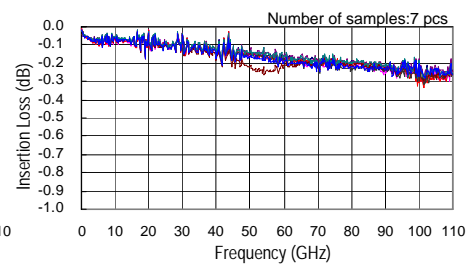
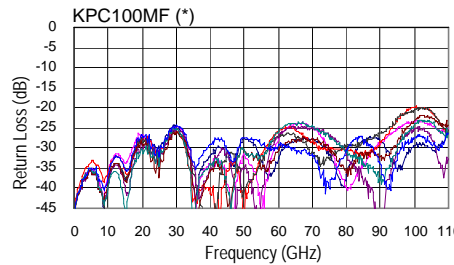
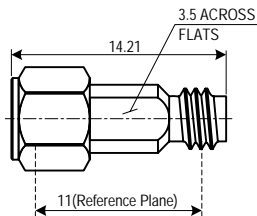

TYPE: KPC100FF 1mm Female/1mm Female

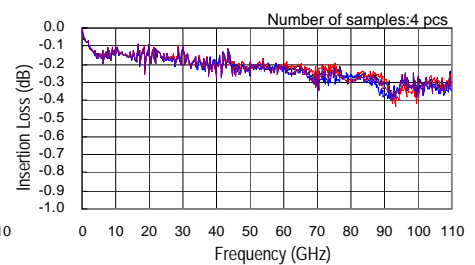
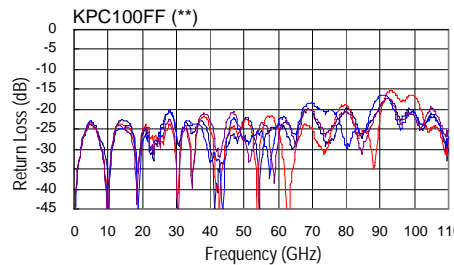
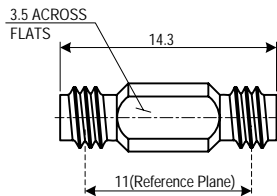

TYPE: KPC100MM 1mm Male/1mm Male

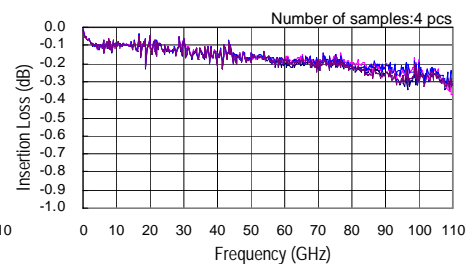
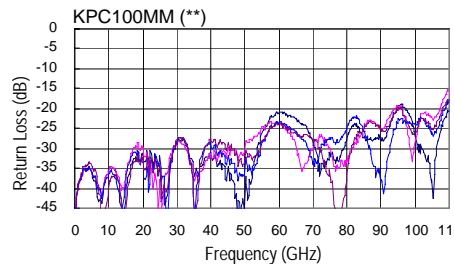
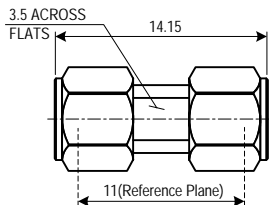

Interface Mating Dimensions of KPC100

Note:

All dimensions are in Millimeters.
 (*) Calibration as *Insertable-Device*
 (**) Calibration as *Non-Insertable-Device*

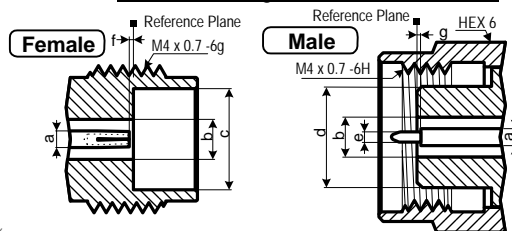

a	φ 0.434
b	φ 1.000
c	φ 2.390
d	φ 2.358
e	φ 0.250
f	0-0.025
g	0-0.025

Specifications Subject to Change Without Notice.

Copyright(C) 2004 KAWASHIMA Mfg. Co., Ltd. All rights reserved.

KPC100MF/FF/MM Rev. 02 Oct. 17.2006



Kawashima Manufacturing Co., Ltd.

1-3-5 Higashiikuta, Tama-ku,
 Kawasaki 214-0031 JAPAN

TEL: +81-44-911-7073 FAX: +81-44-911-9621
 http://www.kmco.biz/ e-mail: sales@kmco.co.jp

1.85mm/1.85mm

DC - 65GHz, Coaxial Adapters, In-Series

DESCRIPTION

These "KPC185MF, FF and MM" coaxial adapters that small size, low SWR and low loss, are designed for broadband measurement, instrument and system use.

SPECIFICATIONS:

Electrical:

Frequency Range	DC - 65 GHz
SWR	<1.3
Insertion Loss	<0.35 dB
Electrical Length	17.5 mm(Nominal)
Temperature Range	-55 to +125 deg.C

Mechanical:

- Body and Outer Conductors:
 - Passivated Stainless steel
- Inner Conductors:
 - Gold Plated Beryllium Copper and Brass
- Coupling Torque 90 N-cm(Nominal)
- Connect/Disconnect Life >1,000 Cycles



Production Status
Two weeks Lead-Time will be available for shipping.

TYPE: KPC185MF 1.85mm Male/1.85mm Female

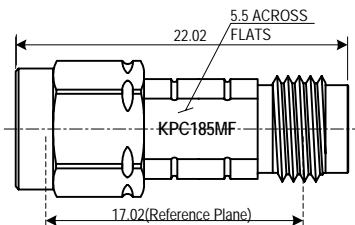

Typical Performance

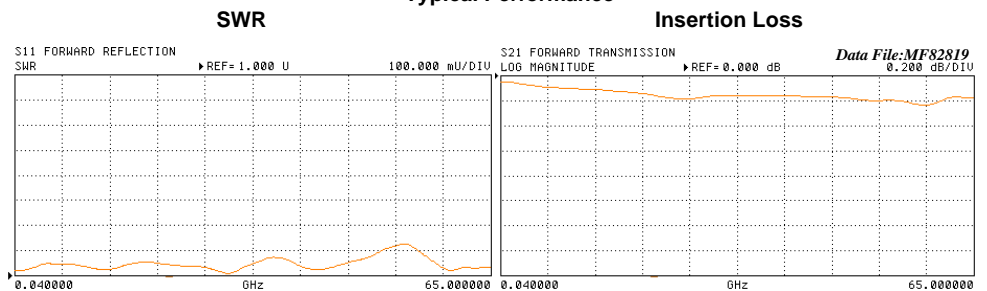

TYPE: KPC185FF 1.85mm Female/1.85mm Female

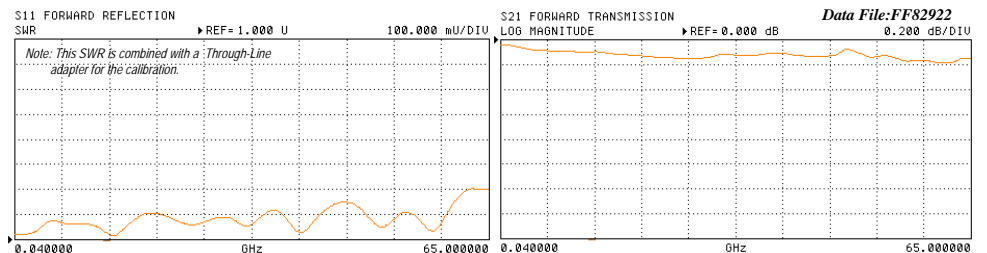
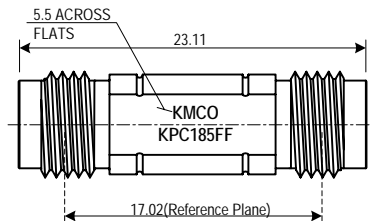

TYPE: KPC185MM 1.85mm Male/1.85mm Male

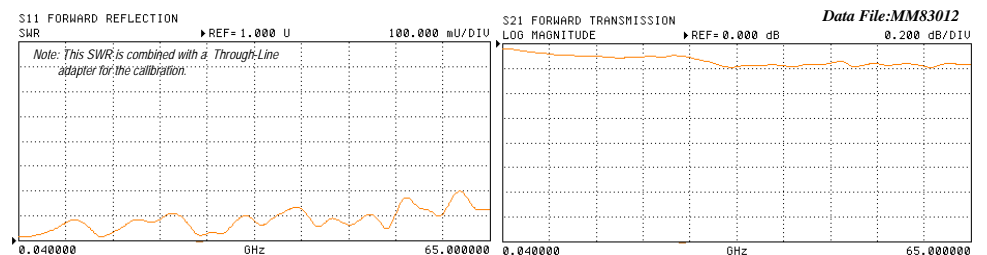
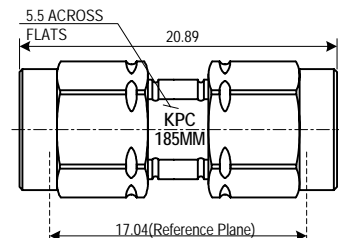

Interface Mating Dimensions of KPC185 (1.85mm Connectors<*>)

Note: All dimensions are in Millimeters.

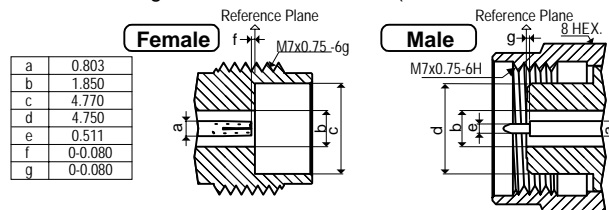

<*> Matable with 2.4mm Connectors

Specifications Subject to Change Without Notice.

Copyright(C) 2002 KAWASHIMA Mfg. Co., Ltd. All rights reserved.

185K Rev. Aug.2002

2.4mm/2.4mm

DC - 50GHz, Coaxial Adapters, In-Series

DESCRIPTION

These "KPC240MF, FF and MM" coaxial adapters that small size, low SWR and low loss, are designed for broadband measurement, instrument and system use.

SPECIFICATIONS:

Electrical:

Frequency Range	DC - 50 GHz
SWR	<1.25
Insertion Loss	<0.3 dB
Electrical Length	17.5 mm(Nominal)
Temperature Range	-55 to +125 deg.C

Mechanical:

- Body and Outer Conductors:
 - Passivated Stainless steel
- Inner Conductors:
 - Gold Plated Beryllium Copper and Brass
- Coupling Torque 90 N-cm(Nominal)
- Connect/Disconnect Life >1,000 Cycles



Production Status
Two weeks Lead-Time will be available for shipping.

TYPE: KPC240MF 2.4mm Male/2.4mm Female

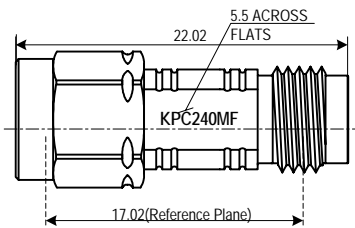

Typical Performance

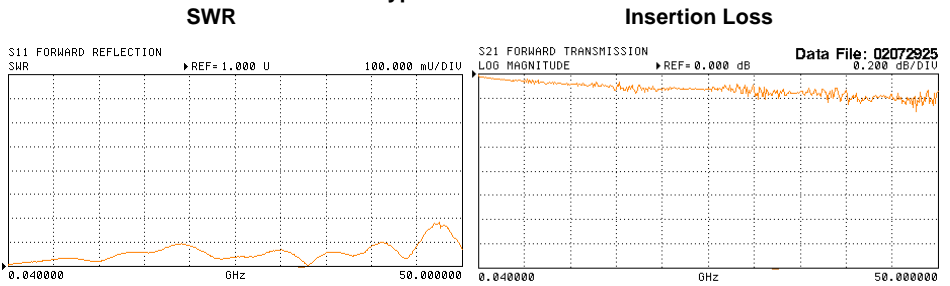

TYPE: KPC240FF 2.4mm Female/2.4mm Female

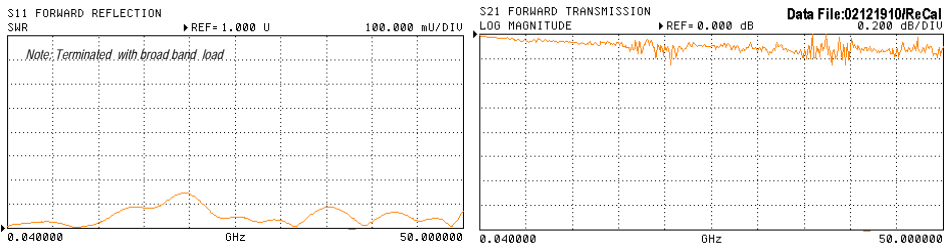
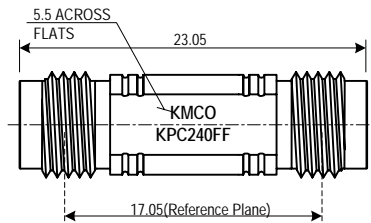

TYPE: KPC240MM 2.4mm Male/2.4mm Male

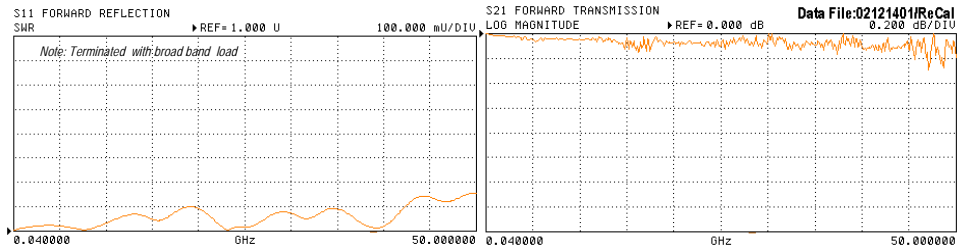
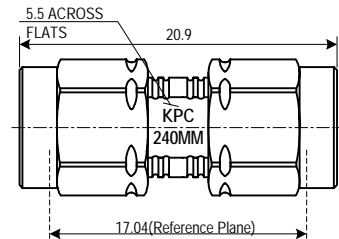

Interface Mating Dimensions of KPC240 (2.4mm Connectors<*>)

Note: All dimensions are in Millimeters.

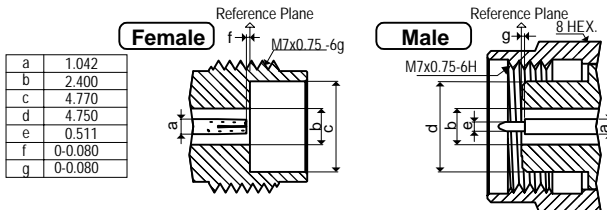

<*> Matable with 1.85mm Connectors

Specifications Subject to Change Without Notice.

Copyright(C) 2002 KAWASHIMA Mfg. Co., Ltd. All rights reserved.

240 Rev. Jan.2003

2.92mm/2.92mm

DC - 40GHz, Coaxial Adapters, In-Series

DESCRIPTION

These "KPC292MF, FF and MM" coaxial adapters that small size, low SWR and low loss, are designed for broadband measurement, instrument and system use.

SPECIFICATIONS:

Electrical:

Frequency Range DC - 40 GHz
 SWR <1.15 (MF & MM)
 <1.20 (FF)
 Insertion Loss <0.2 dB
 Electrical Length 17.5 mm(Nominal)
 Temperature Range -55 to +125 deg.C

Mechanical:

Body and Outer Conductors:
 -Passivated Stainless steel
 Inner Conductors:
 -Gold Plated Beryllium Copper and Brass
 Coupling Torque 90 N-cm(Nominal)
 Connect/Disconnect Life >1,000 Cycles



Production Status
 Two weeks Lead-Time will be available for shipping.

TYPE: KPC292MF 2.92mm Male/2.92mm Female

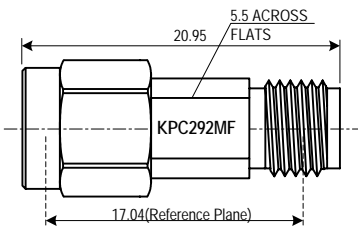

SWR

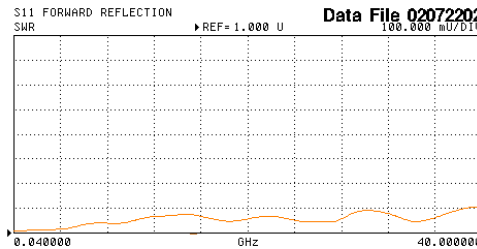

Insertion Loss

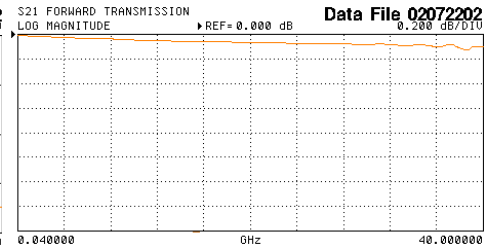

TYPE: KPC292FF 2.92mm Female/2.92mm Female

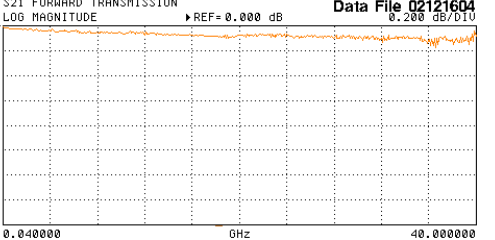
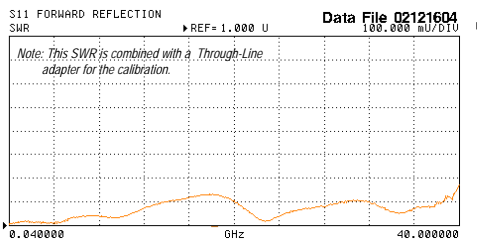
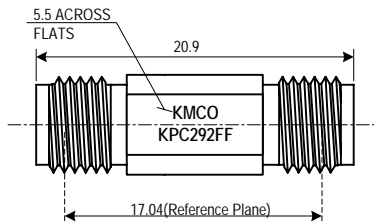

TYPE: KPC292MM 2.92mm Male/2.92mm Male

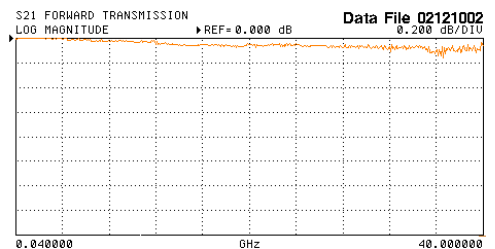
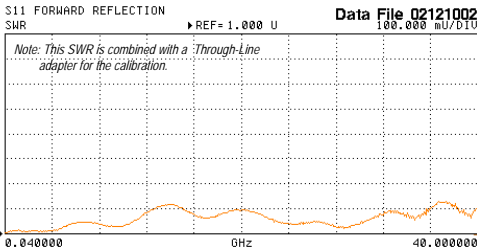
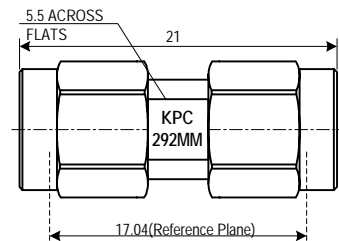

Interface Mating Dimensions of KPC292 (2.92mm Connectors)

Note: All dimensions are in Millimeters.

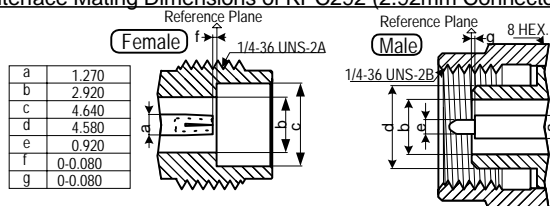

Specifications Subject to Change Without Notice.

Copyright(C) 2002 KAWASHIMA Mfg. Co., Ltd. All rights reserved.

292Rev. Jan.2003

3.5mm/3.5mm

DC - 26.5GHz, Coaxial Adapters, In-Series

DESCRIPTION

These "KPC350MF, FF and MM" coaxial adapters that small size, low SWR and low loss, are designed for broadband measurement, instrument and system use.

SPECIFICATIONS:

Electrical:

Frequency Range DC - 26.5 GHz (Moding: 34GHz)
 SWR < 1.15
 Insertion Loss < 0.2 dB
 Electrical Length 17.5 mm (Nominal)
 Temperature Range -55 to +125 deg.C

Mechanical:

Body and Outer Conductors:
 -Passivated Stainless steel
 Inner Conductors:
 -Gold Plated Beryllium Copper and Brass
 Coupling Torque 90 N-cm (Nominal)
 Connect/Disconnect Life > 1,000 Cycles



Production Status
 Two weeks Lead-Time will be available for shipping.

TYPE: KPC350MF 3.5mm Male/3.5mm Female

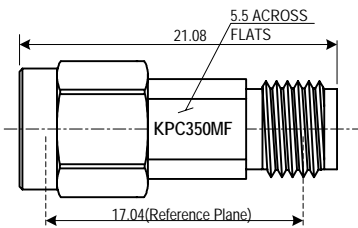

Typical Performance

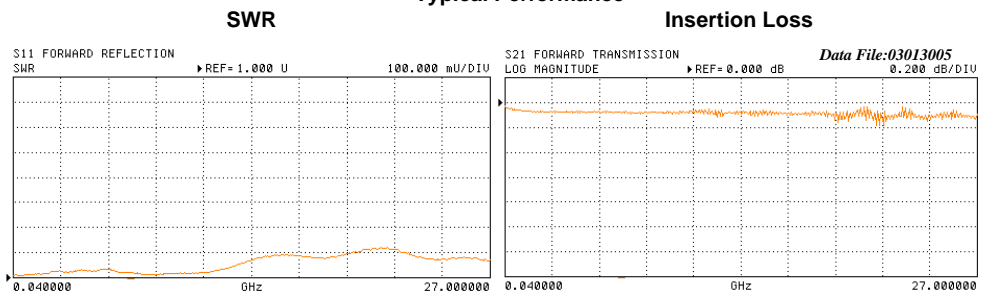

TYPE: KPC350FF 3.5mm Female/3.5mm Female

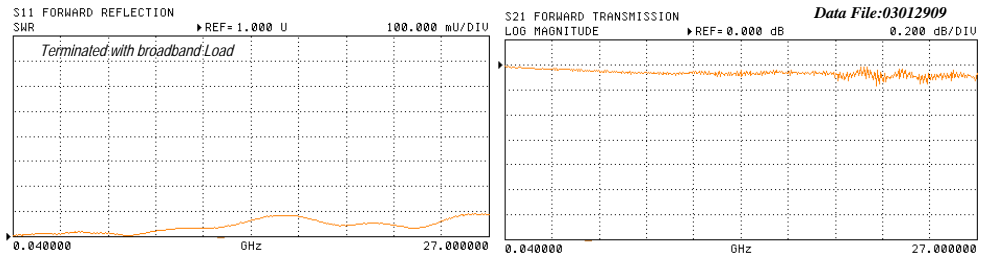
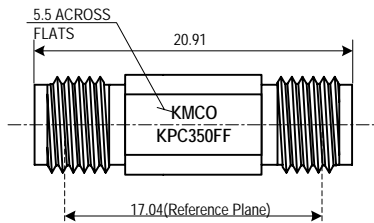

TYPE: KPC350MM 3.5mm Male/3.5mm Male

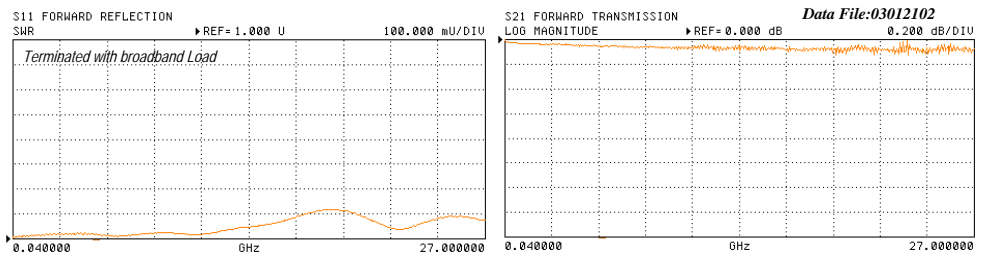
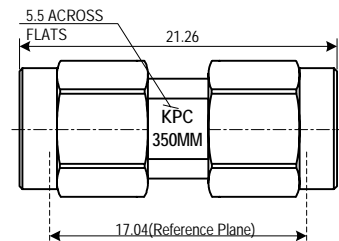

Note: All dimensions are in Millimeters.

Interface Mating Dimensions of KPC350 (3.5mm Connectors <*>)

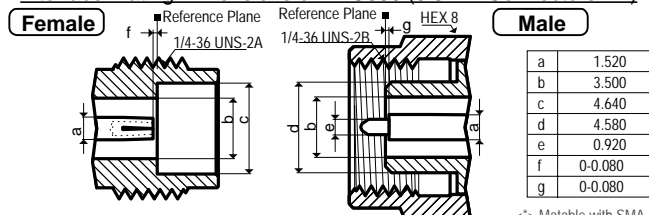

<*> Matable with SMA and 2.92mm Connectors

350_Feb.2003

Specifications Subject to Change Without Notice.

Copyright(C) 2002 KAWASHIMA Mfg. Co., Ltd. All rights reserved.

1.85mm/1mm

DC - 67GHz, Coaxial Adapters, Between-Series

DESCRIPTION

The coaxial adapters between 1.85mm and 1.00mm that small size, low SWR and low loss, are designed for broadband measurement, instrument and system use.

SPECIFICATIONS:

Electrical:

Frequency Range DC - 67 GHz
 Return Loss Better than 16dB ⁽¹⁾
 Insertion Loss <0.6 dB ⁽¹⁾
 Electrical Length 14.6 mm(Nominal)
 Temperature Range -55 to +125

Mechanical:

Body and Outer Conductors:
 -Gold Plated Stainless steel
 Inner Conductors:
 -Gold Plated Beryllium Copper and Brass
 Coupling Torque 90 N-cm for KPC185 (Nominal)
 45 N-cm for KPC100 (Nominal)
 Connect/Disconnect Life >500 Cycles [Predicted]



Performance test configuration

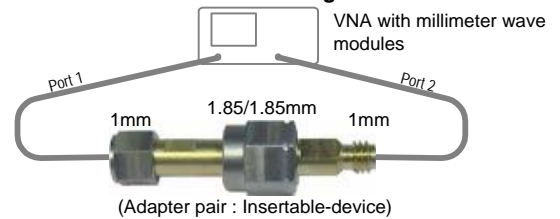

TYPE: KPC185F100F
 1.85mm Female/1mm Female

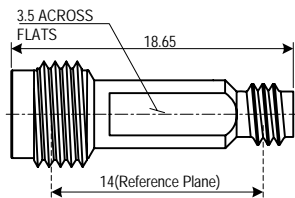

TYPE: KPC185F100M
 1.85mm Female/1mm Male

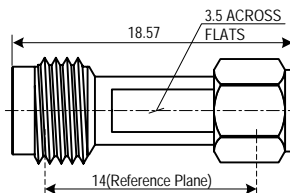

TYPE: KPC185M100F
 1.85mm Male/1mm Female

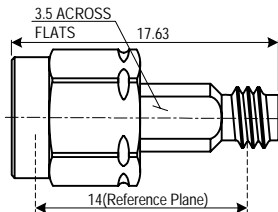

TYPE: KPC185M100M
 1.85mm Male/1mm Male

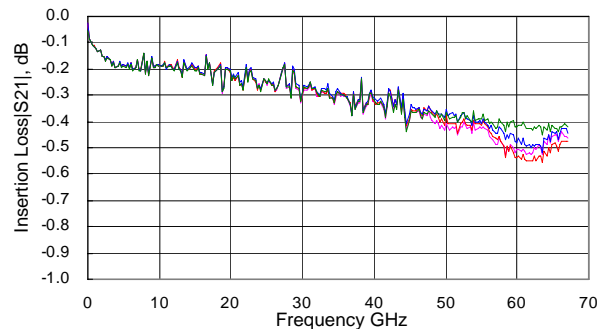
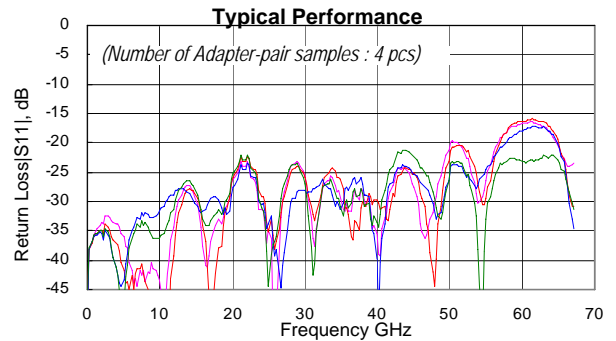
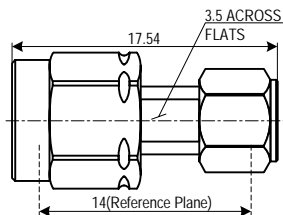

Note:

All dimensions are in Millimeters.

- (1) As for the return loss and insertion loss of the adapters, 1.8mm ports are mated and 1mm ports are measured as an interface.

KPC185(1.85mm)

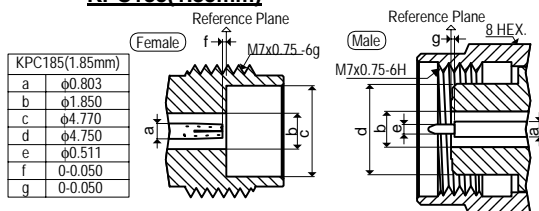

Interface Mating Dimensions

KPC100(1mm)

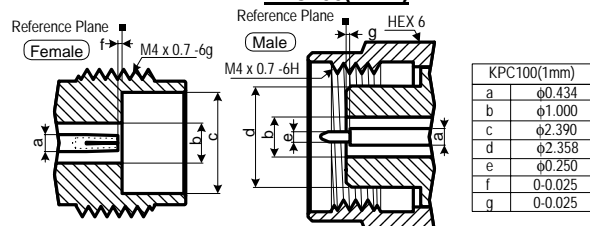

Specifications Subject to Change Without Notice.

Copyright(C) 2004 KAWASHIMA Mfg. Co., Ltd. All rights reserved.

185-100 Rev.02 Oct. 17 2006

2.4mm/1.85mm

DC - 50GHz, Coaxial Adapters, Between-Series

DESCRIPTION

The coaxial adapters between 2.4mm and 1.85mm that small size, low SWR and low loss, are designed for broadband measurement, instrument and system use.

To solve the following SWR degradation, these adapters have been designed.

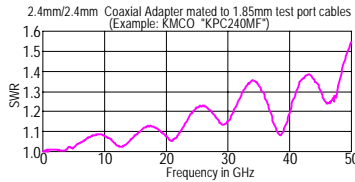

SPECIFICATIONS:

Electrical:

Frequency Range	DC - 50 GHz
SWR	<1.25 (*)
Insertion Loss	<0.4 dB (**)
Electrical Length	17.5 mm(Nominal)
Temperature Range	-55 to +125 deg.C

Mechanical:

Body and Outer Conductors:	-Passivated Stainless steel
Inner Conductors:	-Gold Plated Beryllium Copper and Brass
Coupling Torque	90 N-cm(Nominal)
Connect/Disconnect Life	>1,000 Cycles



Production Status
Two weeks Lead-Time will be available for shipping.

Typical Performance

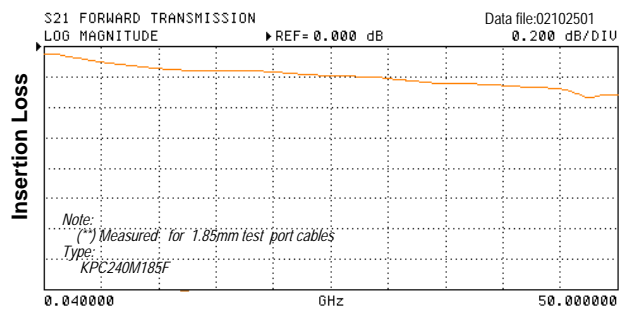
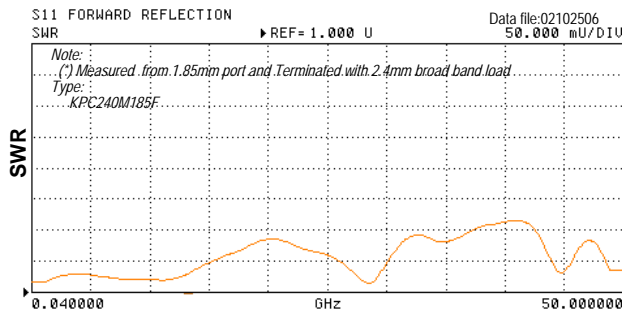

TYPE: KPC240F185F 2.4mm Female/1.85mm Female

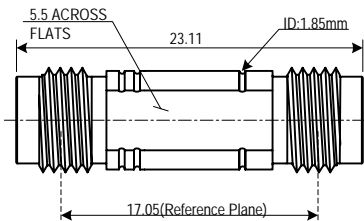

TYPE: KPC240F185M 2.4mm Female/1.85mm Male

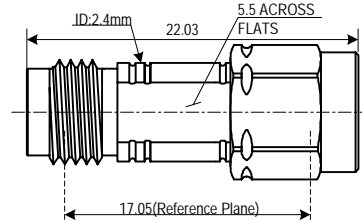

TYPE: KPC240M185F 2.4mm Male/1.85mm Female

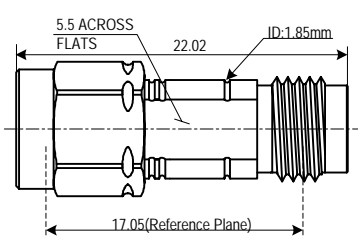

TYPE: KPC240M185M 2.4mm Male/1.85mm Male

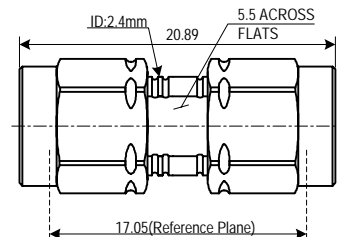

Interface Mating Dimensions KPC240 and 185 Connectors

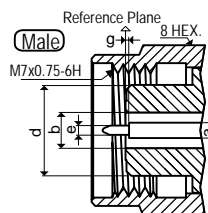
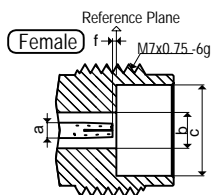

KPC240(2.4mm)	
a	1.042
b	2.400
c	4.770
d	4.750
e	0.511
f	0-0.080
g	0-0.080

KPC185(1.85mm)	
a	0.803
b	1.850
c	4.770
d	4.750
e	0.511
f	0-0.080
g	0-0.080

Note: All dimensions are in Millimeters.

Specifications Subject to Change Without Notice.

Copyright(C) 2002 KAWASHIMA Mfg. Co., Ltd. All rights reserved.

240 185 Rev. Nov.2002

2.92mm/1.85mm

DC - 40GHz, Coaxial Adapters, Between-Series

DESCRIPTION

The coaxial adapters between 2.92mm and 1.85mm that small size, low SWR and low loss, are designed for broadband measurement, instrument and system use.

SPECIFICATIONS:

Electrical:

Frequency Range	DC - 40 GHz
SWR	<1.3
Insertion Loss	<0.35 dB
Electrical Length	17.5 mm(Nominal)
Temperature Range	-55 to +125 deg.C

Mechanical:

- Body and Outer Conductors:
 - Passivated Stainless steel
- Inner Conductors:
 - Gold Plated Beryllium Copper and Brass
- Coupling Torque 90 N-cm(Nominal)
- Connect/Disconnect Life >1,000 Cycles



Production Status
Two weeks Lead-Time will be available for shipping.

Typical Performance

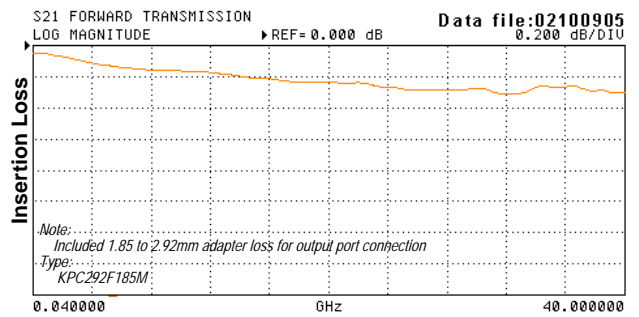
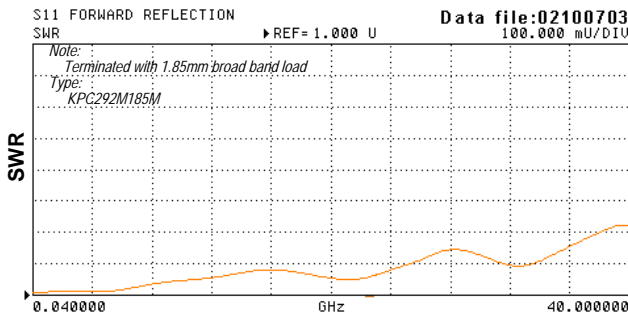

TYPE: KPC292F185F
2.92mm Female/1.85mm Female

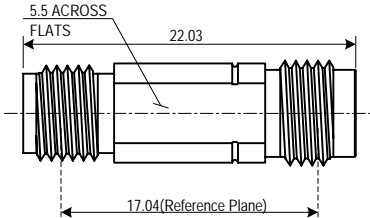

TYPE: KPC292F185M
2.92mm Female/1.85mm Male

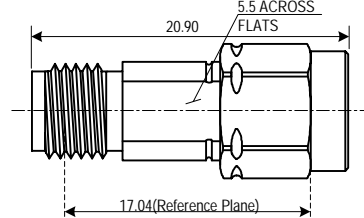

TYPE: KPC292M185F
2.92mm Male/1.85mm Female

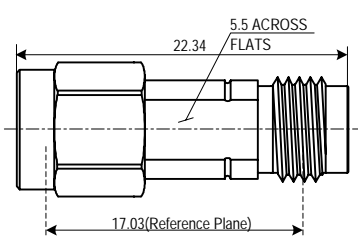

TYPE: KPC292M185M
2.92mm Male/1.85mm Male

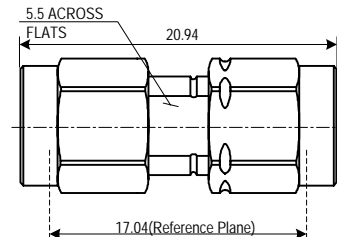

Interface Mating Dimensions

KPC292 (2.92mm Connectors)

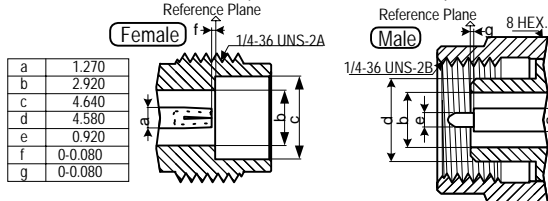

KPC185 (1.85mm Connectors-<*>)

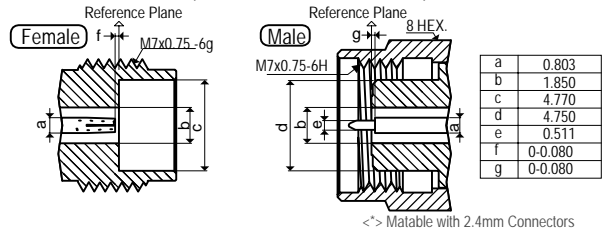

Note: All dimensions are in Millimeters.

Specifications Subject to Change Without Notice.

Copyright(C) 2002 KAWASHIMA Mfg. Co., Ltd. All rights reserved.

292_185 Rev. Oct.2002

2.92mm/2.4mm

DC - 40GHz, Coaxial Adapters, Between-Series

DESCRIPTION

The coaxial adapters between 2.92mm and 2.4mm that small size, low SWR and low loss, are designed for broadband measurement, instrument and system use.

SPECIFICATIONS:

Electrical:

Frequency Range	DC - 40 GHz
SWR	<1.22
Insertion Loss	<0.25dB
Electrical Length	17.5 mm(Nominal)
Temperature Range	-55 to +125 deg.C

Mechanical:

- Body and Outer Conductors:
 - Passivated Stainless steel
- Inner Conductors:
 - Gold Plated Beryllium Copper and Brass
- Coupling Torque 90 N-cm(Nominal)
- Connect/Disconnect Life >1,000 Cycles



Production Status
Two weeks Lead-Time will be available for shipping.

Typical Performance

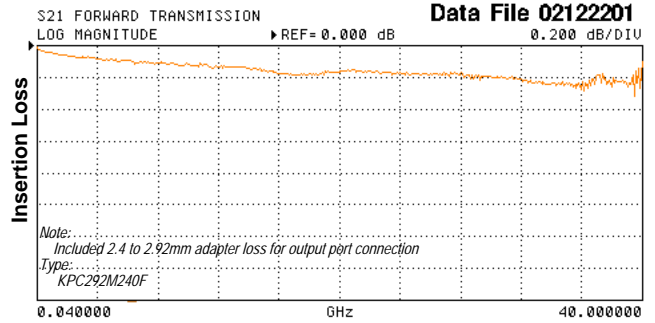
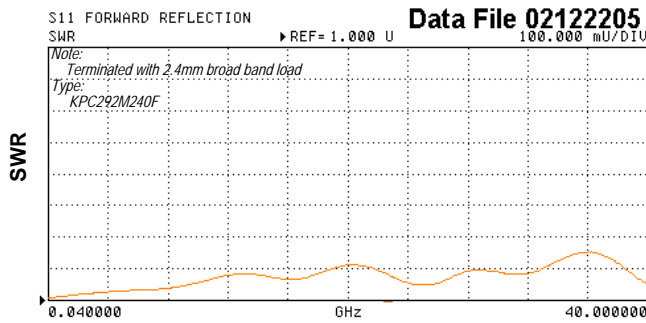

TYPE: KPC292F240F
2.92mm Female/2.4mm Female

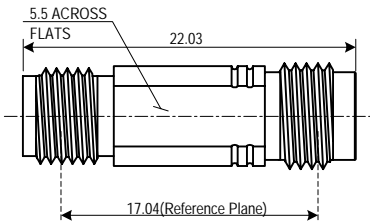

TYPE: KPC292F240M
2.92mm Female/2.4mm Male

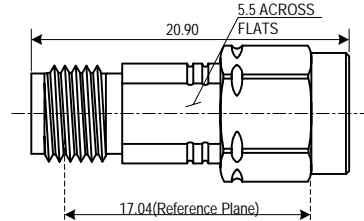

TYPE: KPC292M240F
2.92mm Male/2.4mm Female

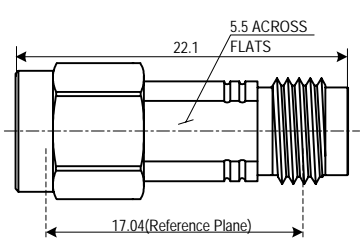

TYPE: KPC292M240M
2.92mm Male/2.4mm Male

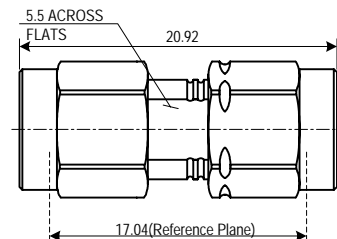

Interface Mating Dimensions

KPC292 (2.92mm Connectors)

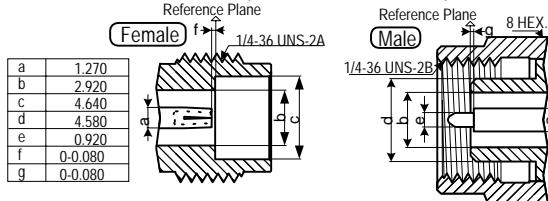

KPC240 (2.4mm Connectors<*>)

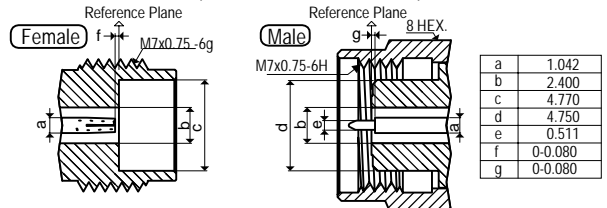

Note: All dimensions are in Millimeters.

Specifications Subject to Change Without Notice.

Copyright(C) 2002 KAWASHIMA Mfg. Co., Ltd. All rights reserved.

292_240 Rev. Jan.2003

3.5mm/2.4mm

DC - 26.5GHz, Coaxial Adapters, Between-Series

DESCRIPTION

The coaxial adapters between 3.5mm and 2.4mm that small size, low SWR and low loss, are designed for broadband measurement, instrument and system use.

SPECIFICATIONS:

Electrical:

Frequency Range DC - 26.5 GHz (Molding: 34GHz)
 SWR < 1.2
 Insertion Loss < 0.3 dB
 Electrical Length 17.5 mm (Nominal)
 Temperature Range -55 to +125 deg.C

Mechanical:

Body and Outer Conductors:
 -Passivated Stainless steel
 Inner Conductors:
 -Gold Plated Beryllium Copper and Brass
 Coupling Torque 90 N-cm (Nominal)
 Connect/Disconnect Life > 1,000 Cycles



Production Status
 Two weeks Lead-Time will be available for shipping.

Typical Performance

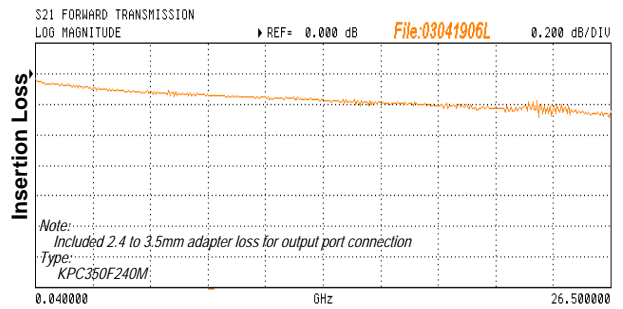
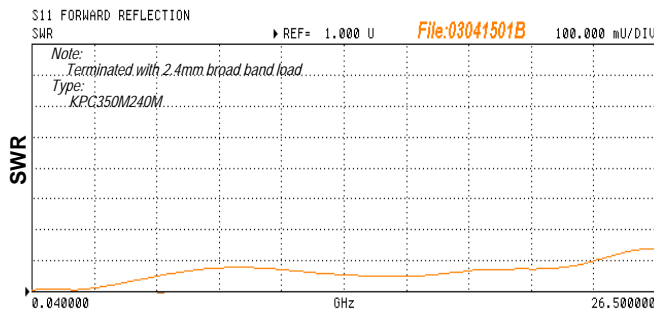

TYPE: KPC350F240F
 3.5mm Female/2.4mm Female

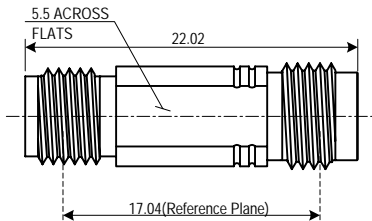

TYPE: KPC350F240M
 3.5mm Female/2.4mm Male

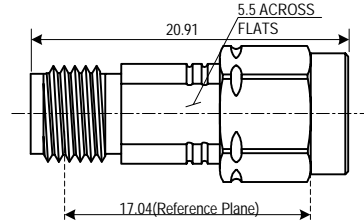

TYPE: KPC350M240F
 3.5mm Male/2.4mm Female

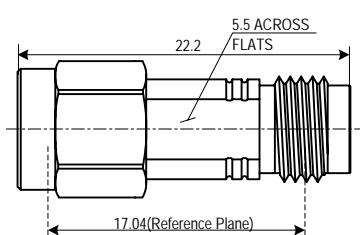

TYPE: KPC350M240M
 3.5mm Male/2.4mm Male

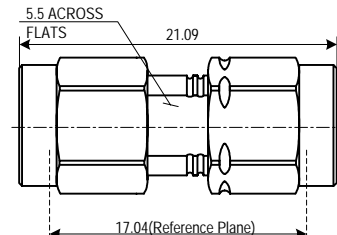

Interface Mating Dimensions

KPC350 (3.5mm Connectors)

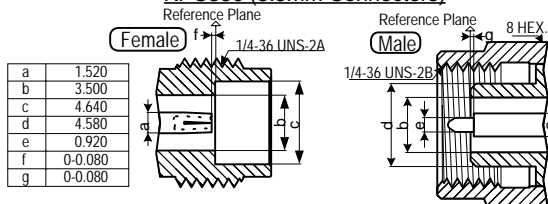

KPC240 (2.4mm Connectors<*>)

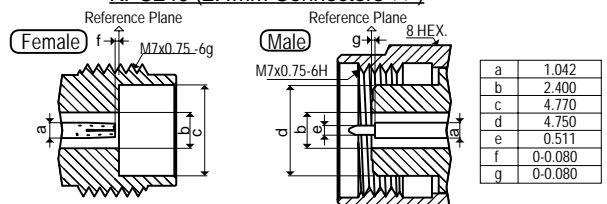

<*> Matable with 1.85mm Connectors

Note: All dimensions are in Millimeters.

Specifications Subject to Change Without Notice.

Copyright(C) 2003 KAWASHIMA Mfg. Co., Ltd. All rights reserved.

350_240 Rev. Sept.2003

1.85mm/1.85mm

DC - 65GHz, Coaxial Panel Adapters For Front Access Ports

DESCRIPTION

This "KPC185MF FPA" called coaxial front panel adapter that easy to mate, low SWR and low loss, are designed for frequently connect/disconnect accessed broadband measurement, instrument and system use.

SPECIFICATIONS:

Electrical:

Frequency Range DC - 65 GHz
 SWR <1.3
 Insertion Loss <0.5 dB
 Electrical Length Below (Nominal)
 Temperature Range -55 to +125 deg.C

Mechanical:

Body: Passivated Stainless steel (*)
 Outer Conductors: Gold Plated Stainless steel
 Inner Conductors: Gold Plated Beryllium Copper
 Coupling Torque 90 N-cm(Nominal)
 Connect/Disconnect Life >1,000 Cycles



Production Status
 Three weeks Lead-Time will be available for shipping.

TYPE: KPC185MF FPA 1.85mm Male/1.85mm Female

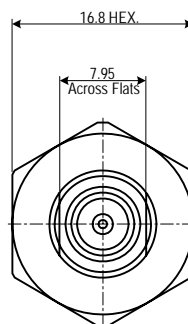
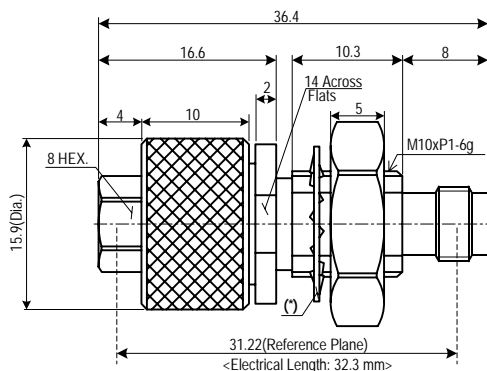

Mounting Hole and Thickness (Recommended)



Thickness: 2 to 5.4mm

Typical Performance

No. of Samples:13pcs

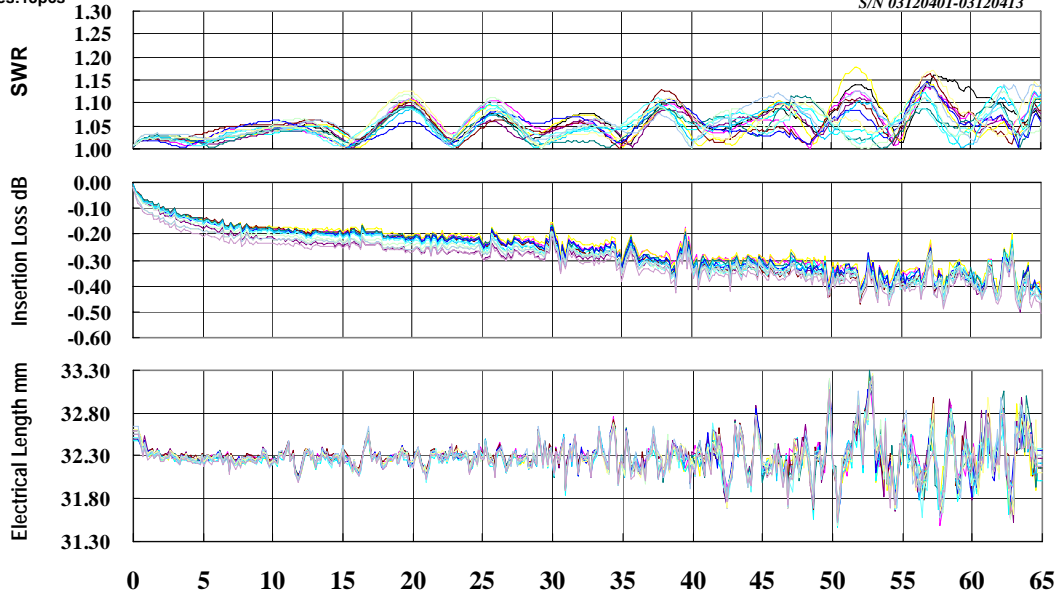

Interface Mating Dimensions of KPC185MF FPA (1.85mm Connectors<*>)

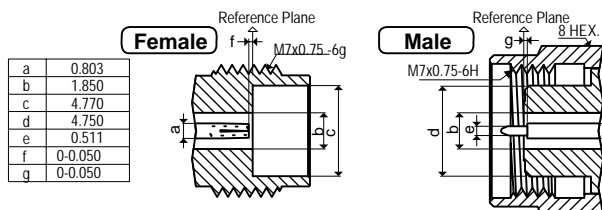

Note:
 - All dimensions are in Millimeters.
 - (*)The toothed lockwasher is nickel plated steel.

<*> Matable with 2.4mm Connectors

Specifications Subject to Change Without Notice.

Copyright(C) 2002-2004 KAWASHIMA Mfg. Co., Ltd. All rights reserved.

185MF FPA Rev.01 Apr.2006

2.92mm/2.92mm

DC - 40GHz, Coaxial Panel Adapters For Front Access Ports

DESCRIPTION

This "KPC292MF FPA" called coaxial front panel adapter that easy to mate, good return loss and low insertin loss, are designed for frequently connect/disconnect accessed broadband measurement, instrument and system use.

SPECIFICATIONS:

Electrical:

Frequency Range	DC - 40 GHz
Return Loss	Better than 26 dB
Insertion Loss	<0.3 dB
Electrical Length	Below (Nominal)
Temperature Range	-55 to +125 deg.C

Mechanical:

Body:	Passivated Stainless steel (*)
Outer Conductors:	Gold Plated Stainless steel
Inner Conductors:	Gold Plated Beryllium Copper
Coupling Torque	90 N-cm(Nominal)
Connect/Disconnect Life	>1,000 Cycles



Production Status
Three weeks Lead-Time will be available for shipping.

TYPE: KPC292MF FPA 2.92mm Male/2.92mm Female

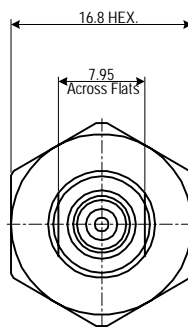
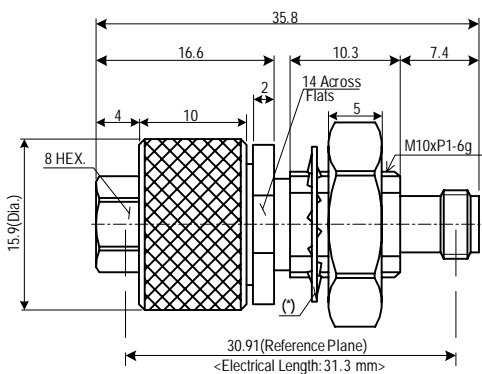

Mounting Hole and Thickness
(Recommended)

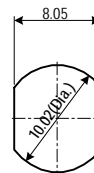

Thickness: 2 to 5.4mm

Typical Performance

No. of Samples: 7 pcs

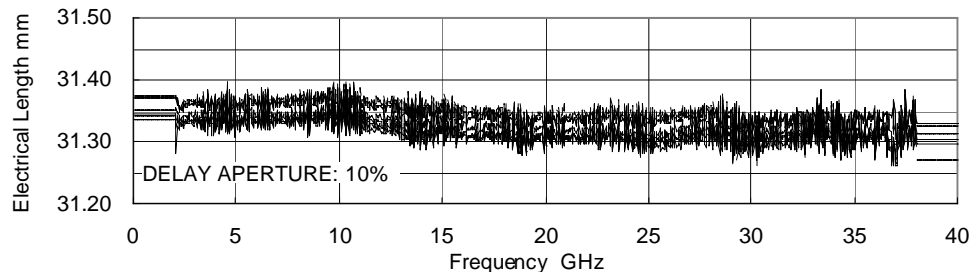
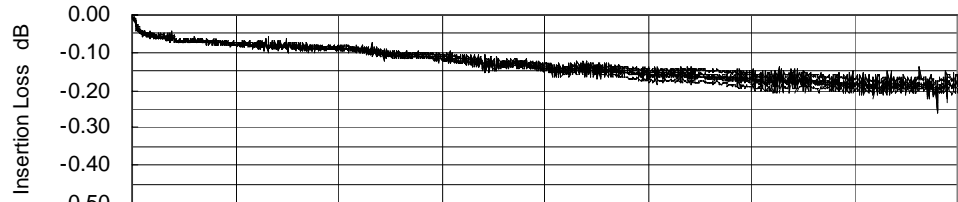
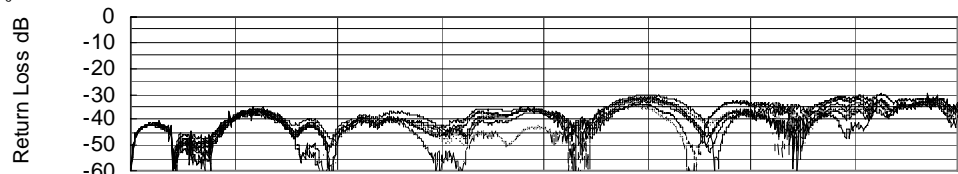

Interface Mating Dimensions of KPC292 (2.92mm Connectors)

Note:

- All dimensions are in Millimeters.
- (*)The toothed lockwasher is nickel plated steel.

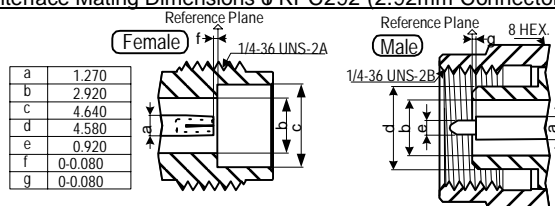

< * Matable with 3.5mm and SMA

Specifications Subject to Change Without Notice.

Copyright(C) 2002-2007 KAWASHIMA Mfg. Co., Ltd. All rights reserved.

292MF FPA Rev.00 JLY.2007

1.85mm/1.85mm

DC - 65GHz, Coaxial Panel Adapters

DESCRIPTION

These "KPC185MFPA,FFPA and MMPA" coaxial panel adapters that 9.5mm "D" holed panel mountable, low SWR and low loss, are designed for broadband measurement, instrument and system use.

SPECIFICATIONS:

Electrical:

Frequency Range DC - 65 GHz
 SWR <1.3
 Insertion Loss <0.4 dB
 Electrical Length Below (Nominal)
 Temperature Range -55 to +125 deg.C

Mechanical:

Body and Outer Conductors:
 -Passivated Stainless steel (*)
 Inner Conductors:
 -Gold Plated Beryllium Copper and Brass
 Coupling Torque 90 N-cm(Nominal)
 Connect/Disconnect Life >1,000 Cycles



Production Status
 Two weeks Lead-Time will be available for shipping.

TYPE: KPC185MFPA

1.85mm Male/1.85mm Female

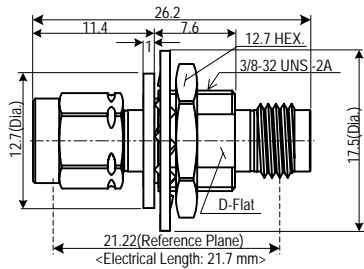

SWR

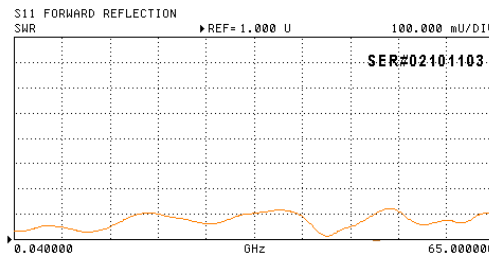

Typical Performance

Insertion Loss

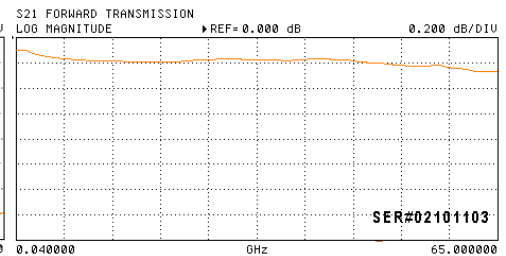

TYPE: KPC185FFPA

1.85mm Female/1.85mm Female

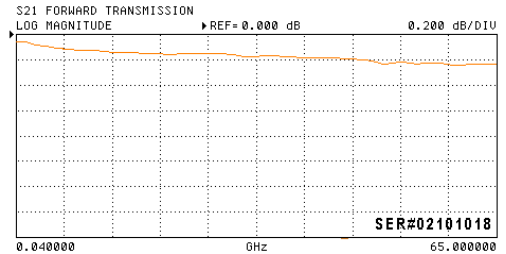
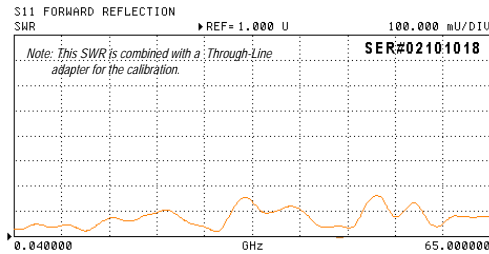
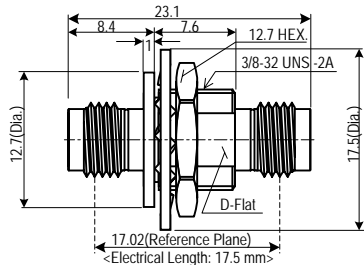

TYPE: KPC185MMPA

1.85mm Male/1.85mm Male

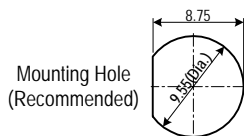
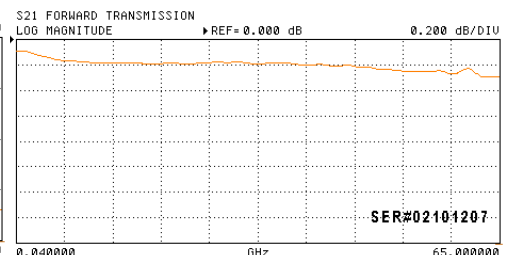
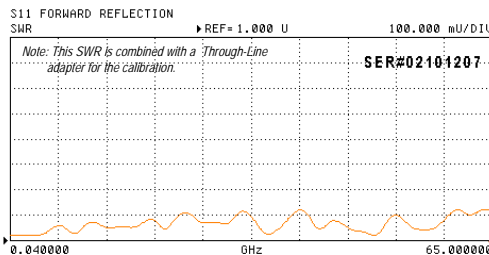
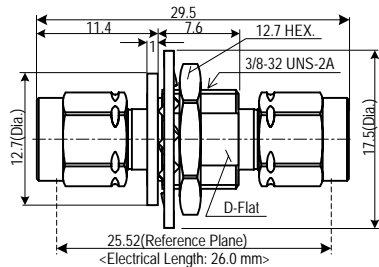

Note:
 - All dimensions are in Millimeters.
 - (*)The toothed lockwasher is chromate converted zinc plated steel.

Interface Mating Dimensions of KPC185 (1.85mm Connectors<->)

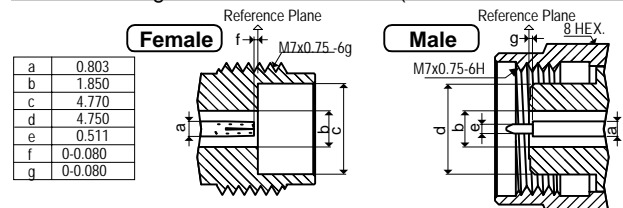

<-> Matable with 2.4mm Connectors

Specifications Subject to Change Without Notice.

Copyright(C) 2002 KAWASHIMA Mfg. Co., Ltd. All rights reserved.

185pa Rev...Sep.2002

2.92mm/2.92mm

DC - 40GHz, Coaxial Panel Adapters

DESCRIPTION

These "KPC292MFPA,FFPA and MMPA" coaxial panel adapters that 9.5mm "D" holed panel mountable, low SWR and low loss, are designed for broadband measurement, instrument and system use.

SPECIFICATIONS:

Electrical:

Frequency Range	DC - 40 GHz
SWR	<1.15
Insertion Loss	<0.25 dB
Electrical Length	Below (Nominal)
Temperature Range	-55 to +125 deg.C

Mechanical:

Body	: Passivated Stainless steel (*)
Outer Conductors	: Gold Plated Stainless steel
Inner Conductors	: Gold Plated Beryllium Copper
Coupling Torque	90 N·cm(Nominal)
Connect/Disconnect Life	>1,000 Cycles



Production Status
Two weeks Lead-Time will be available for shipping.

TYPE: KPC292MFPA

2.92mm Male/2.92mm Female

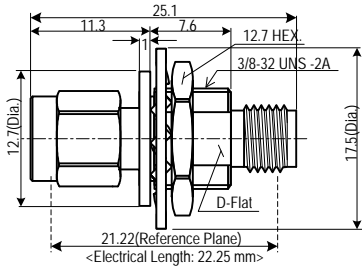

Typical Performance

KPC292MFPA

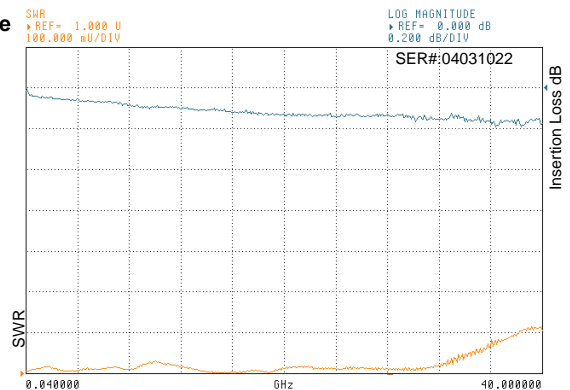

TYPE: KPC292FFPA

2.92mm Female/2.92mm Female

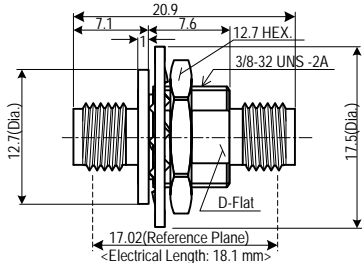

KPC292FFPA

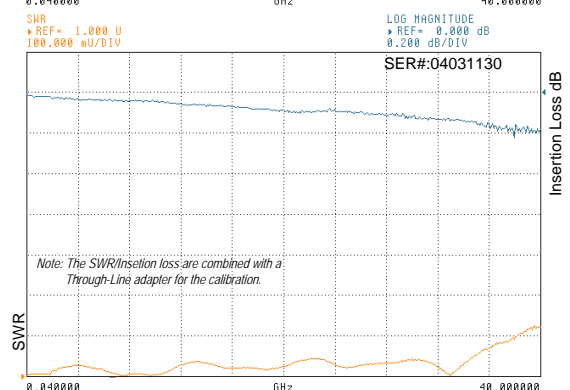

TYPE: KPC292MMPA

2.92mm Male/2.92mm Male

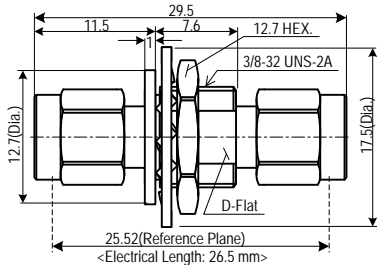

KPC292MMPA

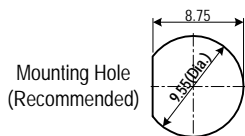
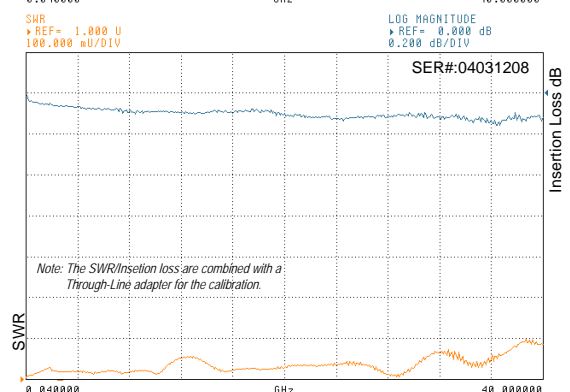

Note:
- All dimensions are in Millimeters.
- (*)The toothed lockwasher is chromate converted zinc plated steel.

Interface Mating Dimensions of KPC292 (2.92mm Connectors)

a	1.270
b	2.920
c	4.640
d	4.580
e	0.920
f	0-0.050
g	0-0.050

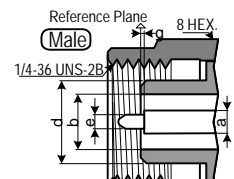
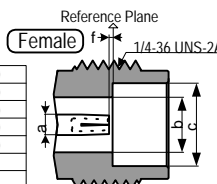

Specifications Subject to Change Without Notice.

Copyright(C) 2002-2004 KAWASHIMA Mfg. Co., Ltd. All rights reserved.

1.85mm/1.85mm

DC - 65GHz, Hermetically Sealed, Coaxial Adapter

DESCRIPTION

This "KPC185FFHA " Hermetically Sealed 1.85mm to 1.85mm Coaxial Adapter that

- DC to 65GHz,
- Low SWR and loss,
- Hermetic RF interface between vacuum and atmosphere environment,
- Small mounting space,

is designed for broadband devices, instrument and component testing use.

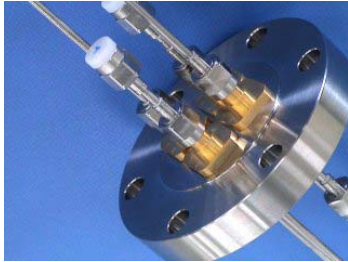

ex. of 4-Adapters mounted to 70mm dia. vacuum flange.

SPECIFICATIONS:

Electrical:

Frequency Range	DC - 65 GHz
Return Loss	>15 dB
Insertion Loss	<0.7 dB
Electrical Length	Below (Nominal)
Temperature Range	-55 to +125 deg.C

Mechanical:

- Body and Outer Conductors:
 - Gold Plated Stainless steel
- Inner Conductors:
 - Gold Plated Beryllium Copper
- Inner and Outer Conductors for seal:
 - Gold Plated Fe/Ni/Co Alloy(KOVAR)
- Insulator for seal: #7070 Glass(Corning)
- Gasket for flange seal: Fluoroelastomer "O" Ring
- Coupling Torque 90 N-cm(Nominal)
- Connect/Disconnect Life >1,000 Cycles
- He leak rate(*) 1×10^{-10} Pa³/Sec (1×10^{-9} atm cc /Sec)



Production Status
4 weeks Lead-Time will be available for shipping.

TYPE: KPC185FFHA

1.85mm Female/1.85mm Female

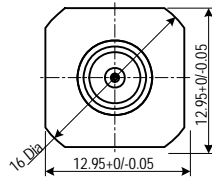
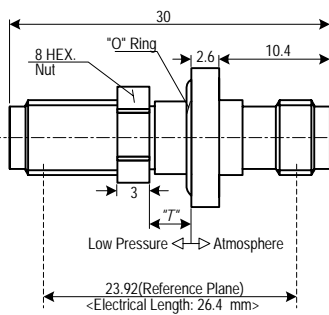

*"T" : Vacuum wall or Flange thickness, 4(min) to 8(max) mm

Typical Performance

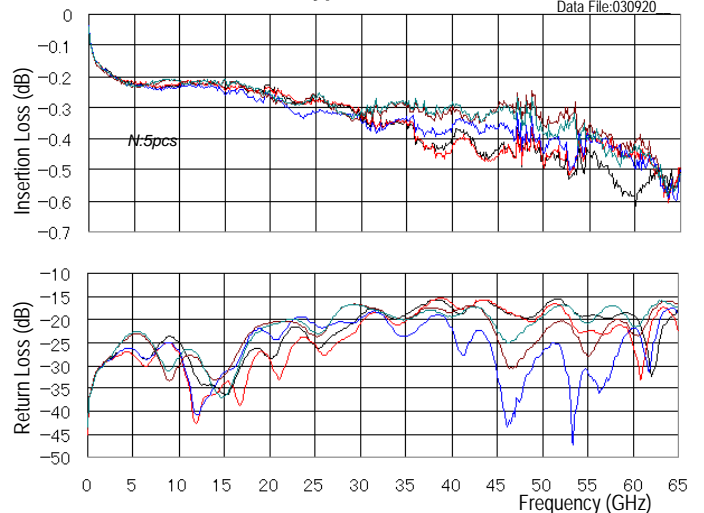

Recommended Mounting Hole and Installation

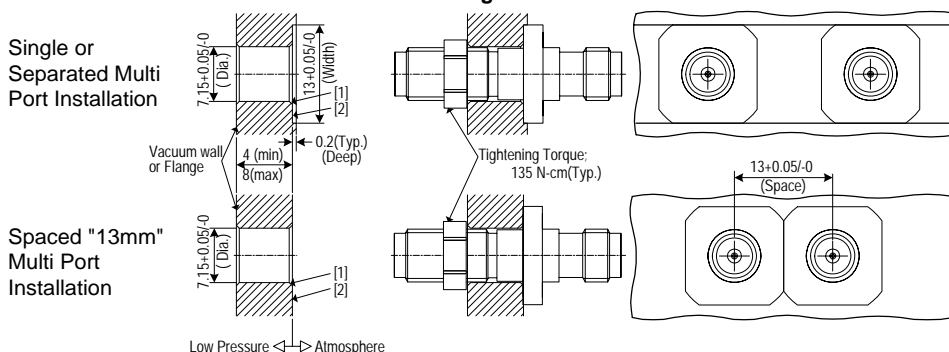

Note:

- All dimensions are in Millimeters.
- [1] Corners : Less than 0.05 x 0.05 mm
- [2] Required "Smooth Surface"
- (*) As Per MIL-STD-883E, METHOD1014.10, Test Condition A4

Interface Mating Dimensions of KPC185 (1.85mm Connectors\leftarrow*)

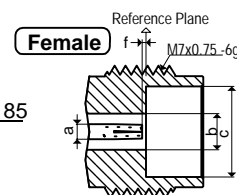

a	0.803
b	1.850
c	4.770
d
e
f	0-0.080
g

\leftarrow Matable with 2.4mm Connectors

Specifications Subject to Change Without Notice.

Copyright(C) 2006 KAWASHIMA Mfg. Co., Ltd. All rights reserved.



Kawashima Manufacturing Co., Ltd.

1-3-5 Higashiikuta, Tama-ku,
Kawasaki 214-0031 JAPAN

TEL: +81-44-911-7073
http://www.kmco.biz/

FAX: +81-44-911-9621
e-mail: sales@kmco.co.jp

185FFHA Rev01 Mar. 2006

2.92mm/2.92mm

DC - 40GHz, Hermetically Sealed, Coaxial Adapter

DESCRIPTION

This "KPC292FFHA " Hermetically Sealed 2.92mm to 2.92mm Coaxial Adapter that

- DC to 40GHz,
- Low SWR and loss,
- Hermetic RF interface between vacuum and atmosphere environment,
- Small mounting space,

is designed for broadband devices, instrument and component testing use.



SPECIFICATIONS:

Electrical:

Frequency Range DC - 40 GHz
 Return Loss >15 dB
 Insertion Loss <0.45 dB
 Electrical Length Below (Nominal)
 Temperature Range -55 to +125 deg.C

Mechanical:

Body and Outer Conductors:
 - Gold Plated Stainless steel and Brass
 Inner Conductors:
 - Gold Plated Beryllium Copper
 Inner and Outer Conductors for seal:
 - Gold Plated Fe/Ni/Co Alloy(KOVAR)
 Insulator for seal: #7070 Glass(Corning)
 Gasket for flange seal: Fluoroelastomer "O" Ring
 Coupling Torque 90 N-cm(Nominal)
 Connect/Disconnect Life >1,000 Cycles
 He leak rate(*) <1x10⁻¹⁰ Pam³/Sec (<1x10⁻⁹ atm cc /Sec)



Production Status
 4 weeks Lead-Time will be available for shipping.

TYPE: KPC292FFHA

2.92mm Female/2.92mm Female

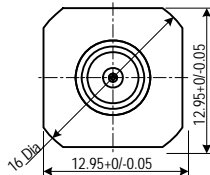
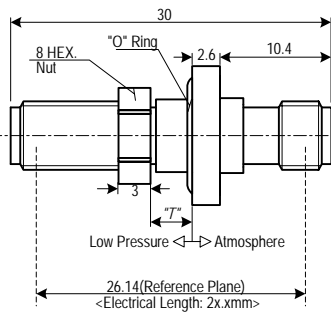

T: Vacuum wall or Flange thickness, 4(min) to 8(max) mm

Typical Performance

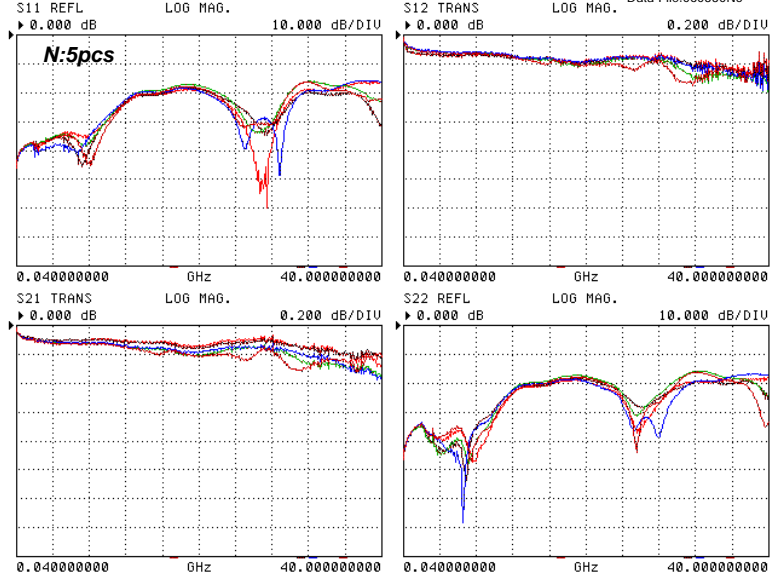

Recommended Mounting Hole and Installation

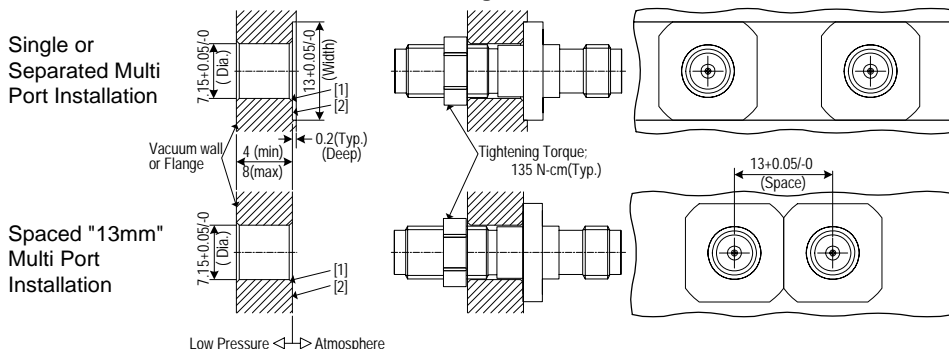

Note:

- All dimensions are in Millimeters.
- [1] Chamfer: Less than 0.05 mm
- [2] Required "Smooth Surface"
- (*) As Per MIL-STD-883E, METHOD1014.10, Test Condition A4

Interface Mating Dimensions of KPC292 (2.92mm Connectors<*>)

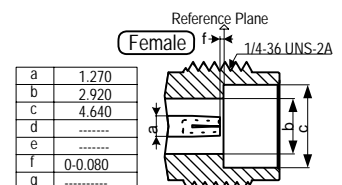

a	1.270
b	2.920
c	4.640
d	-----
e	-----
f	0-0.080
g	-----

<*> Matable with 3.5mm and SMA

Specifications Subject to Change Without Notice.

Copyright(C) 2006 KAWASHIMA Mfg. Co., Ltd. All rights reserved.

292FFHA Rev. - Mar. 2006



Kawashima Manufacturing Co., Ltd.

1-3-5 Higashiikuta, Tama-ku,
 Kawasaki 214-0031 JAPAN

TEL: +81-44-911-7073
 http://www.kmco.biz/

FAX: +81-44-911-9621
 e-mail: sales@kmco.co.jp

3.5mm/3.5mm

DC - 26.5GHz, Push-On Coaxial Adapter For Quick Test

DESCRIPTION

The "KPC350MFPO" push-on coaxial adapter that
 -Easy and quick connection/disconnection
 -To reduce test time
 are designed for broadband component test and system test use.

Push-on port mates onto 3.5mm, 2.92mm and SMA female connectors.

(*) The electrical length is same as KMCO KPC350MF and KPC292MF adapters.

SPECIFICATIONS:

Electrical:

Frequency Range DC - 26.5 GHz(Moding:34GHz)
 Return Loss Better than 22 dB
 Insertion Loss <0.6dB
 Electrical Length 17.5 mm(Nominal)(*)
 Temperature Range -55 to +125 deg.C

Mechanical:

Body and Outer Conductors:
 -Passivated Stainless Steel
 Blind Outer Conductor:
 -Hard Nickel Plated Beryllium Copper
 Inner Conductors:
 -Gold Plated Beryllium Copper and Brass
 Push/Pull Force: 20 N (Typical)
 Connect/Disconnect Life >1,000 Cycles



Production Status
 Two weeks Lead-Time will be available for shipping.

TYPE: KPC350MFPO

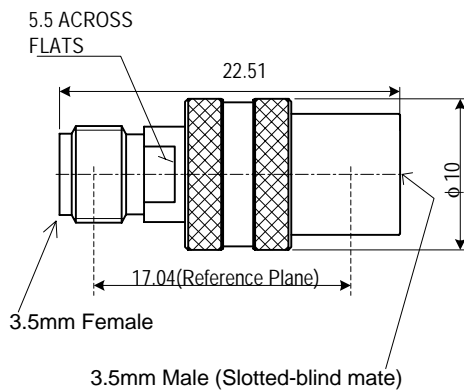

Typical Performance

(As Insertable-device calibration)

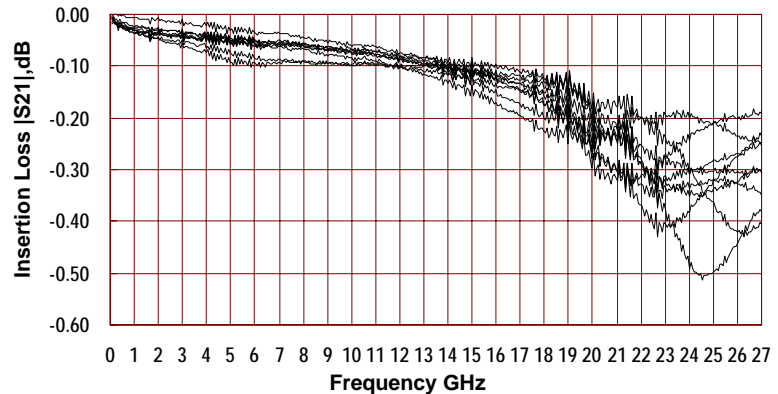
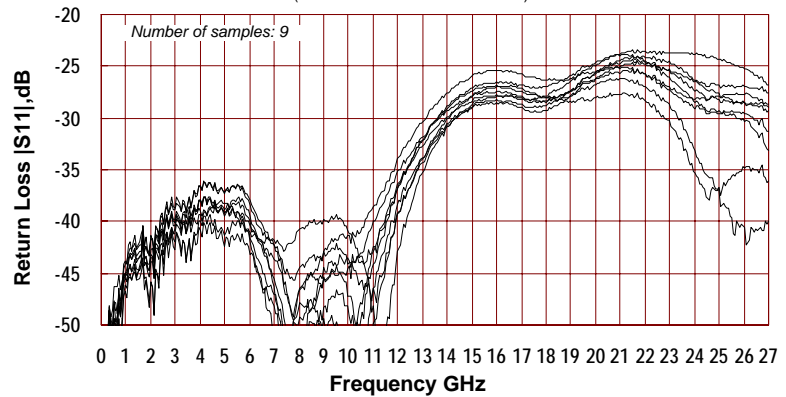

Interface Mating Dimensions of KPC350 (3.5mm Connectors<*>)

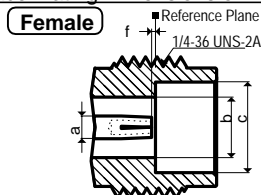

a	1.520
b	3.500
c	4.640
d	-----
e	-----
f	0-0.080
g	-----

Note: All dimensions are in Millimeters.

<*> Matable with SMA and 2.92mm Connectors

Specifications Subject to Change Without Notice.

Copyright(C) 2004 KAWASHIMA Mfg. Co., Ltd. All rights reserved.

350MFPO Rev.00 Aug.27 2004



Kawashima Manufacturing Co., Ltd.

1-3-5 Higashiikuta, Tama-ku,
 Kawasaki 214-0031 JAPAN

TEL: +81-44-911-7073 FAX: +81-44-911-9621
 http://www.kmco.biz/ e-mail: sales@kmco.co.jp

1.85mm

DC - 65GHz, Sparkplug Launcher Connectors & Glass Bead

DESCRIPTION

"KPC185M301/KPC185M301H and KPC185F301/KPC185F301H" sparkplug launcher connectors and "GB185" glass bead are designed for broadband devices and units with coaxial I/O interfaces.

SPECIFICATIONS:

Connectors

Electrical:

Frequency Range DC - 65 GHz
Return Loss >15 dB(*)
Temperature Range -55 to +125 deg.C

Mechanical:

Body and Outer Conductors:
-Passivated Stainless steel
Inner Conductors:
-Gold Plated Beryllium Copper and Brass
Coupling Torque 90 N-cm(Nominal)
Connect/Disconnect Life >1,000 Cycles

Glass Bead

Electrical:

Frequency Range DC - 65 GHz
Temperature Range -55 to +125 deg.C

Mechanical:

Outer and inner Conductors:
-Gold Plated(**) Fe/Ni/Co Alloy (KOVAR)
Insulator: #7070 Glass(Corning)

Others:

Soldering temperature 330 deg.C(max)
He leak rate 1×10^{-10} Pa·m³/sec



Production Status
Two weeks Lead-Time will be available for shipping.

Typical Performance

Note:
(*) As std DUT configuration

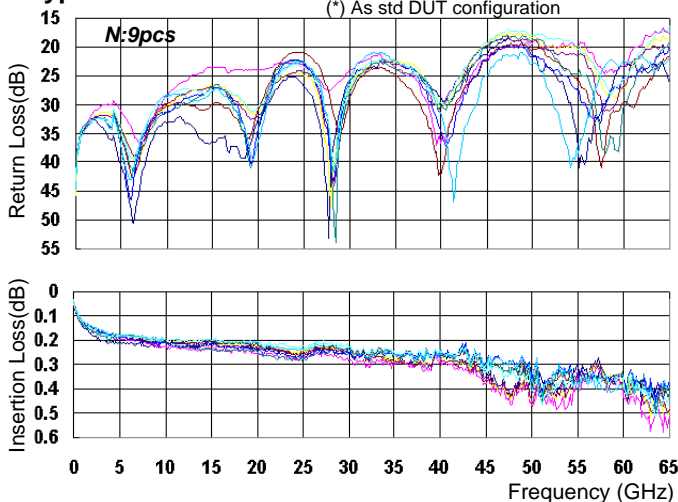

Test configuration

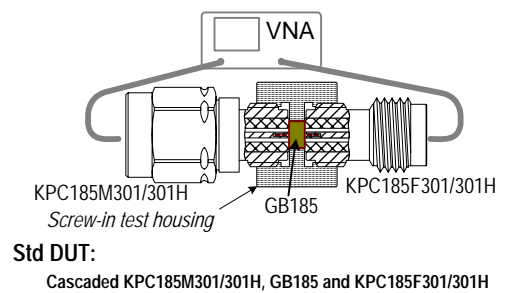

TYPE: KPC185M301

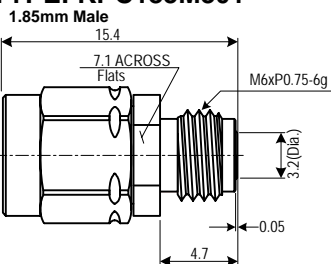

TYPE: KPC185F301

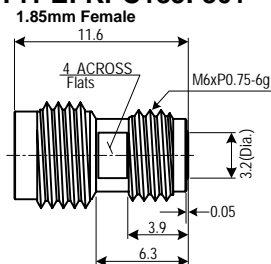

TYPE: KPC185M301H

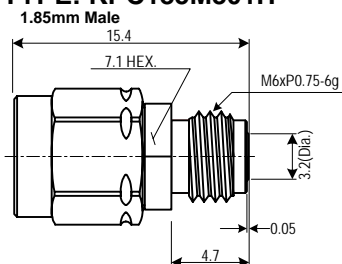

TYPE: KPC185F301H

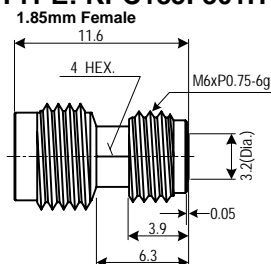

Note:
- All dimensions are in Millimeters.
- (***) Thermo-Sonic wire bondable gold plating

TYPE: GB185 Glass Bead

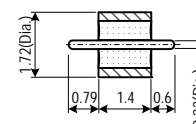

Interface Mating Dimensions of KPC185M301 & KPC185F301 Launchers<*>

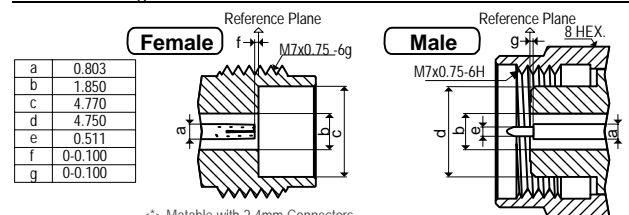

<*> Matable with 2.4mm Connectors

185/301GB Rev.02 Sep.2006

Specifications Subject to Change Without Notice.

Copyright(C) 2002-2006 KAWASHIMA Mfg. Co., Ltd. All rights reserved.



Kawashima Manufacturing Co., Ltd.

1-3-5 Higashiikuta, Tama-ku,
Kawasaki 214-0031 JAPAN

TEL: +81-44-911-7073 FAX: +81-44-911-9621
http://www.kmco.biz/ e-mail: sales@kmco.co.jp

2.92mm

DC - 40GHz, Sparkplug Launcher Connectors & Glass Bead

DESCRIPTION

"KPC292M301 and KPC292F301" sparkplug launcher connectors and "GB292" glass bead are designed for broadband devices and units with coaxial I/O interfaces.



SPECIFICATIONS:

Connectors

Electrical:

Frequency Range DC - 40 GHz
Return Loss >15 dB(*)
Temperature Range -55 to +125 deg.C

Mechanical:

Body and Outer Conductors:
-Passivated Stainless steel
Inner Conductors:
-Gold Plated Beryllium Copper and Brass
Coupling Torque 90 N-cm(Nominal)
Connect/Disconnect Life >1,000 Cycles

Glass Bead

Electrical:

Frequency Range DC - 40 GHz
Temperature Range -55 to +125 deg.C

Mechanical:

Outer and inner Conductors:
-Gold Plated(**) Fe/Ni/Co Alloy (KOVAR)
Insulator: #7070 Glass(Corning)

Others:

Soldering temperature 330 deg.C(max)
He leak rate <math><1 \times 10^{-10}</math> P_{am}³/sec



Production Status
Two weeks Lead-Time will be available for shipping.

Typical Performance Note: (*) As std DUT configuration

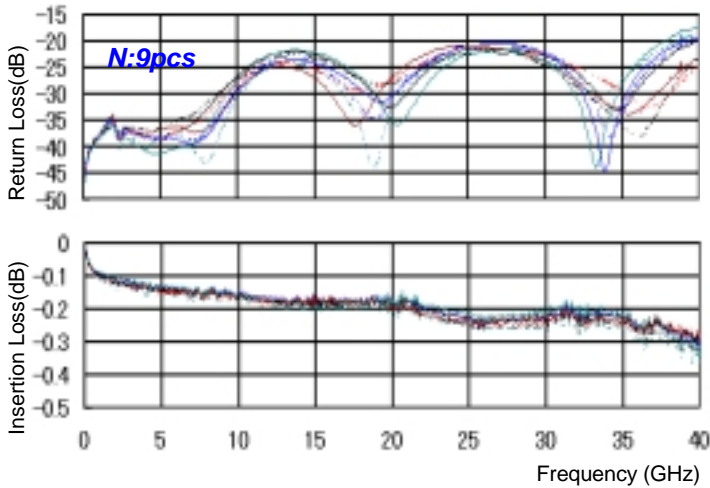

Test configuration

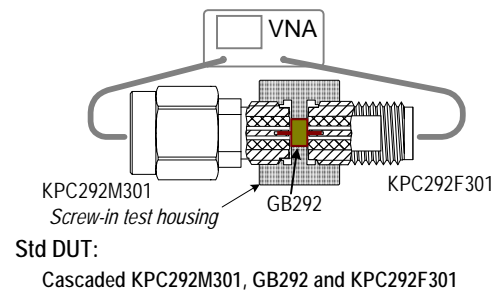

TYPE: KPC292M301

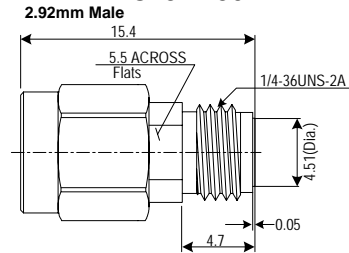

TYPE: KPC292F301

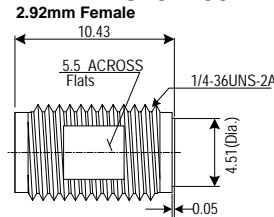

TYPE: GB292 Glass Bead

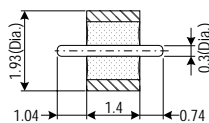

Interface Mating Dimensions of KPC292 (2.92mm Connectors)

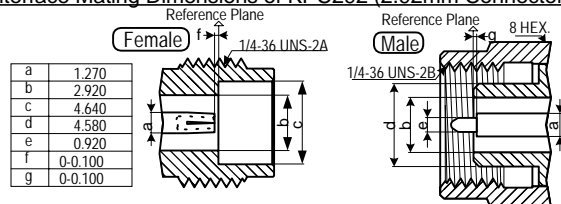

Note:
- All dimensions are in Millimeters.
- (**) Thermo-Sonic wire bondable gold plating

Specifications Subject to Change Without Notice.

Copyright(C) 2002 KAWASHIMA Mfg. Co., Ltd. All rights reserved.

292/301GB Rev.01 Aug.2003

1mm

DC - 110GHz, Flange Launchers

DESCRIPTION

"KPC100F311 and KPC100M311" flange launchers are designed for ultra-broadband devices and units with coaxial I/O interfaces.

SPECIFICATIONS:

Electrical:

Frequency Range DC - 110 GHz
 Return Loss Better than 15 dB (*)
 Insertion Loss <0.7dB (*)
 Electrical Length 11.1 mm [Nominal]
 Temperature Range -55 to +125 Deg.C ⁽¹⁾

Mechanical:

Body and Outer Conductors:
 -Gold Plated Stainless steel
 Inner Conductors:
 -Gold Plated Beryllium Copper and Brass
 Coupling Torque 45 N-cm(Nominal)
 Connect/Disconnect Life >500 Cycles [Predicted]



TYPE: KPC100F311 1mm Female

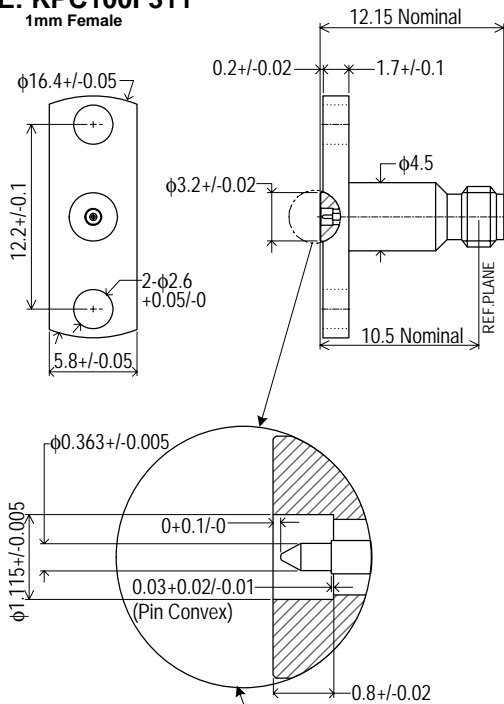

TYPE: KPC100M311 1mm Male

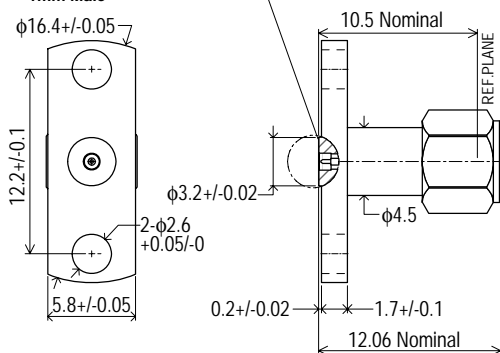

Std Test configuration

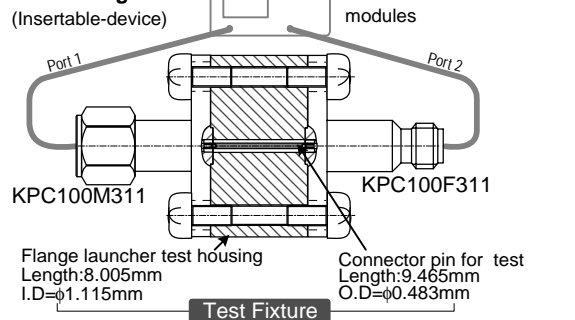

Typical Performance

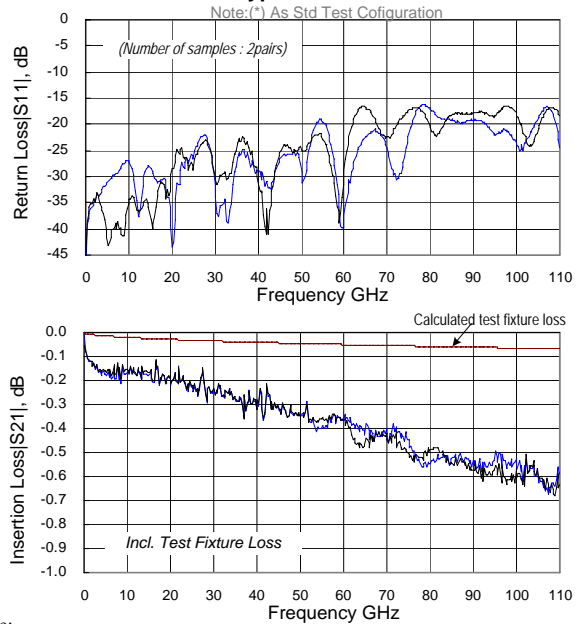

Note:
 - All dimensions are in Millimeters.
 - (1) Temperature Range, short period:200 deg.C
 - (2) Tip of PIN to be touching "Pin Convex" in final assembly

Interface Mating Dimensions of KPC100

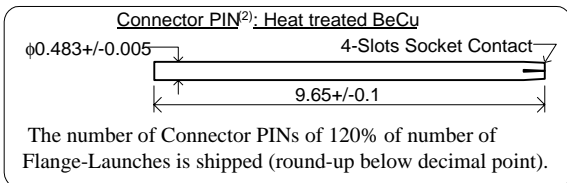
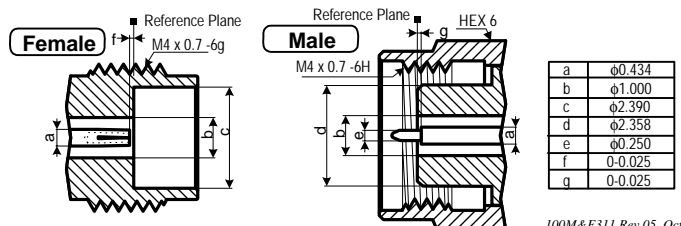

The number of Connector PINs of 120% of number of Flange-Launches is shipped (round-up below decimal point).

Specifications Subject to Change Without Notice.

Copyright(C) 2004 KAWASHIMA Mfg. Co., Ltd. All rights reserved.



Kawashima Manufacturing Co., Ltd.

1-3-5 Higashiikuta, Tama-ku,
 Kawasaki 214-0031 JAPAN

TEL: +81-44-911-7073 FAX: +81-44-911-9621
 http://www.kmco.biz/ e-mail: sales@kmco.co.jp

100M&F311 Rev.05 Oct.17 2006

1.85mm

DC - 65GHz, Two-hole Flange Launchers & Glass Bead

DESCRIPTION

"KPC185M302 and KPC185F302" Two-hole Flange Launchers and "GB185" glass bead are designed for broadband devices and units with coaxial I/O interfaces.

SPECIFICATIONS:

Connectors

Electrical:

Frequency Range DC - 65 GHz
Return Loss >15 dB(*)
Temperature Range -55 to +125 deg.C

Mechanical:

Body and Outer Conductors:
-Passivated Stainless steel
Inner Conductors:
-Gold Plated Beryllium Copper and Brass
Coupling Torque 90 N-cm(Nominal)
Connect/Disconnect Life >1,000 Cycles

Glass Bead

Electrical:

Frequency Range DC - 65 GHz
Temperature Range -55 to +125 deg.C

Mechanical:

Outer and Inner Conductors:
-Gold Plated(**) Fe/Ni/Co Alloy (KOVAR)
Insulator: #7070 Glass(Corning)

Others:

Soldering temperature 330 deg.C(max)
He leak rate 1×10^{-10} Pa·m³/sec



Production Status
Two weeks Lead-Time will be available for shipping.

Typical Performance Note: (*) As std DUT configuration

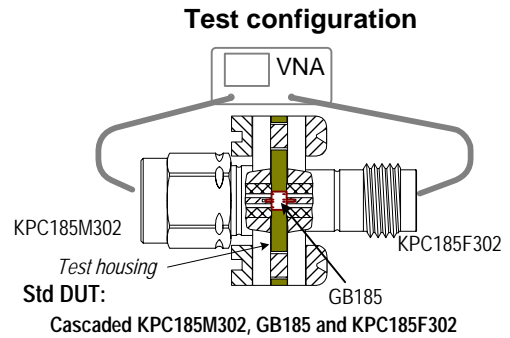
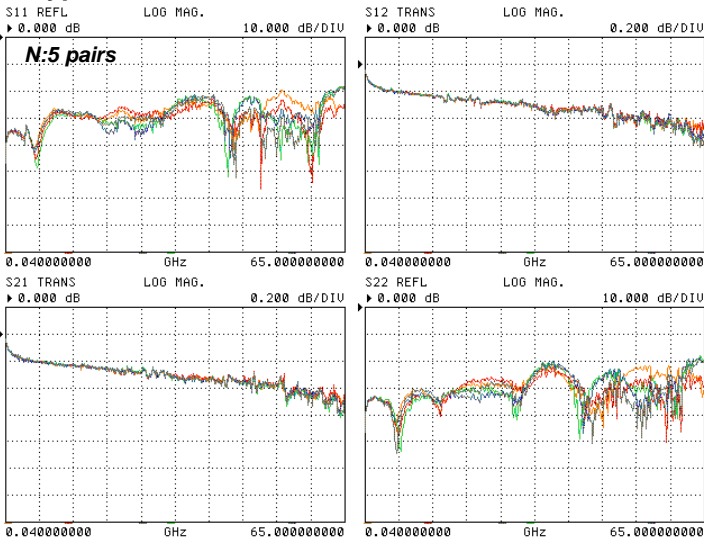

TYPE: KPC185M302 1.85mm Male

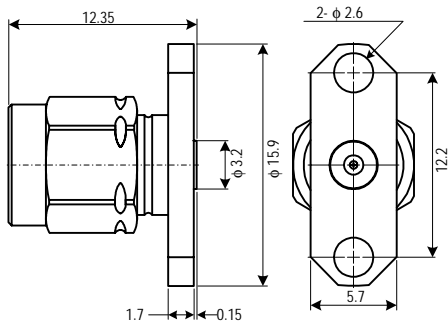

TYPE: KPC185F302 1.85mm Female

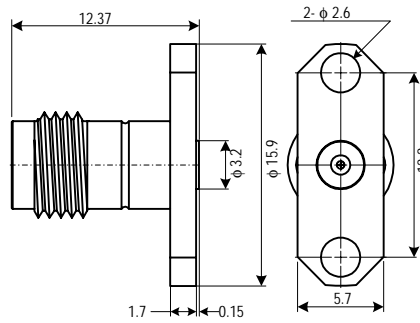

TYPE: GB185 Glass Bead

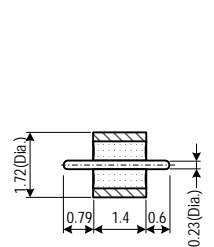

Note:
- All dimensions are in Millimeters.
- (**) Thermo-Sonic wire bondable gold plating

Interface Mating Dimensions of KPC185M302 & KPC185F302 Launchers<*>

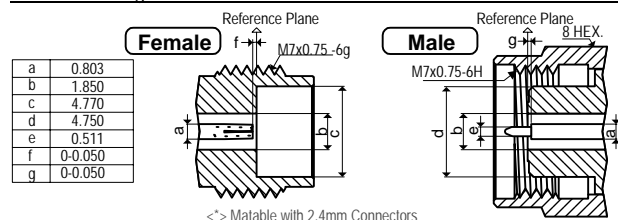

<*> Matable with 2.4mm Connectors

185M/F302-GB185_Rev.00_Mar.2005

Specifications Subject to Change Without Notice.

Copyright(C) 2005 KAWASHIMA Mfg. Co., Ltd. All rights reserved.



Kawashima Manufacturing Co., Ltd.

1-3-5 Higashiikuta, Tama-ku,
Kawasaki 214-0031 JAPAN

TEL: +81-44-911-7073 FAX: +81-44-911-9621
http://www.kmco.biz/ e-mail: sales@kmco.co.jp

2.92mm

DC - 40GHz, Two-hole Flange Launchers & Glass Bead

DESCRIPTION

"KPC292M302 and KPC292F302" Two-hole Flangelauncher connectors and "GB292" glass bead are designed for broadband devices and units with coaxial I/O interfaces.

SPECIFICATIONS:

Connectors

Electrical:

Frequency Range DC - 40 GHz
Return Loss >15 dB(*)
Temperature Range -55 to +125 deg.C

Mechanical:

Body and Outer Conductors:
-Passivated S stainless steel
Inner Conductors:
-Gold Plated Beryllium Copper and Brass
Coupling Torque 90 N-cm(Nominal)
Connect/Disconnect Life >1,000 Cycles

Glass Bead

Electrical:

Frequency Range DC - 40 GHz
Temperature Range -55 to +125 deg.C

Mechanical:

Outer and inner Conductors:
-Gold Plated(**) Fe/Ni/Co Alloy (KOVAR)
Insulator: #7070 Glass (Corning)

Others:

Soldering temperature 330 deg.C(max)
He leak rate <1x10⁻¹⁰ Pa·m³/sec



Production Status
Two weeks Lead-Time will be available for shipping.

Typical Performance Note: (*) As std DUT configuration

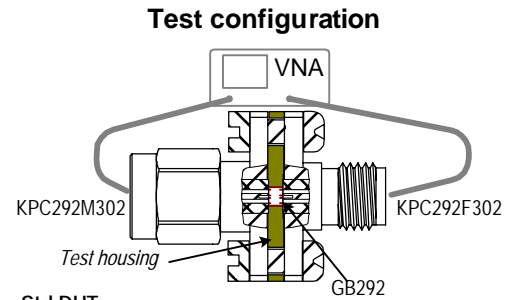
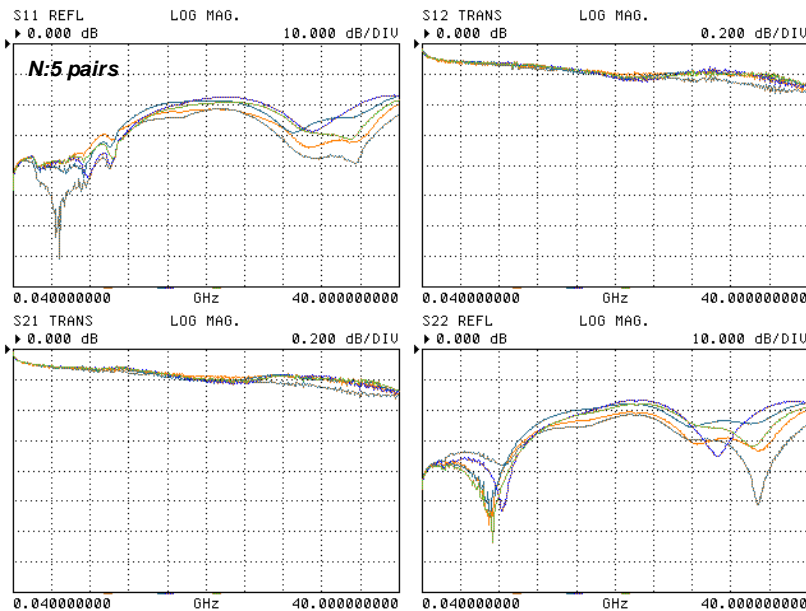

Std DUT:
Cascaded KPC292M302, GB292 and KPC292F302

TYPE: KPC292M302

2.92mm Male

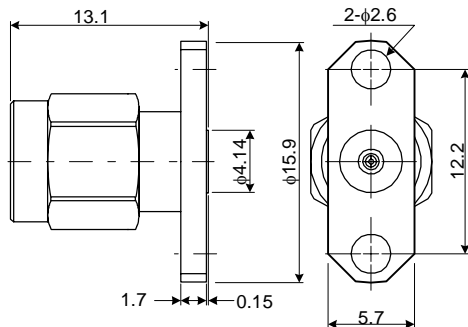

TYPE: KPC292F302

2.92mm Female

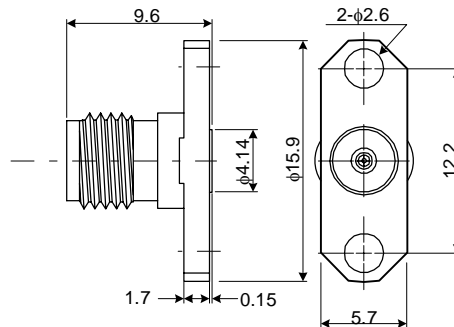

TYPE: GB292

Glass Bead

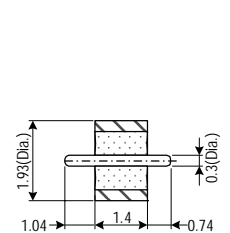

Interface Mating Dimensions of KPC292 (2.92mm Connectors)

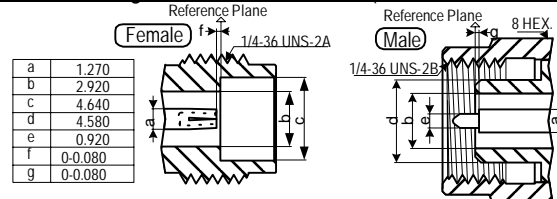

Note:
- All dimensions are in millimeters.
- (***) Thermo-Sonicwire bondable gold plating

Specifications Subject to Change Without Notice.

Copyright(C) 2007 KAWASHIMA Mfg. Co., Ltd. All rights reserved.

292/302GB Rev.02 Mar.2007

Connector Interface 1 mm for DC - 110GHz

DESCRIPTION The Re-Formable Semirigid Cable Assemblies, up to 110 GHz, easy to install with bending by hand on your Labs./Sites, are designed for broadband measurement, instrument and system use.
All materials are "lead free".

SPECIFICATIONS:

- Insertion Loss : See Fig.1
- Return Loss : Better than 17dB
- Temperature Range : -55 to 100 deg.C
- Length (L) : 30 to 200mm +/-1mm [*]
(Up to 200mm, Considerable)

[*] Please specify length(L: □□□□ see following table), when you order this item.
For example: CA100MM0035 (Length:35mm)



Production Status
Two weeks Lead-Time will be available for shipping.

TYPE	Dimension	Connector
CA100FF □□□□		1 mm Female/Female
CA100MF □□□□		1 mm Male/Female
CA100MM □□□□		1 mm Male/Male

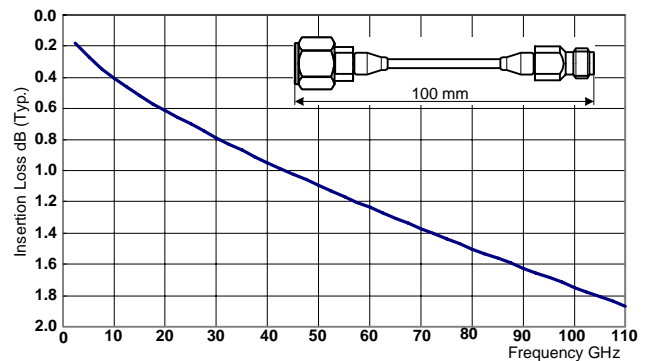

Fig.1 Frequency vs Insertion Loss, Length=100mm

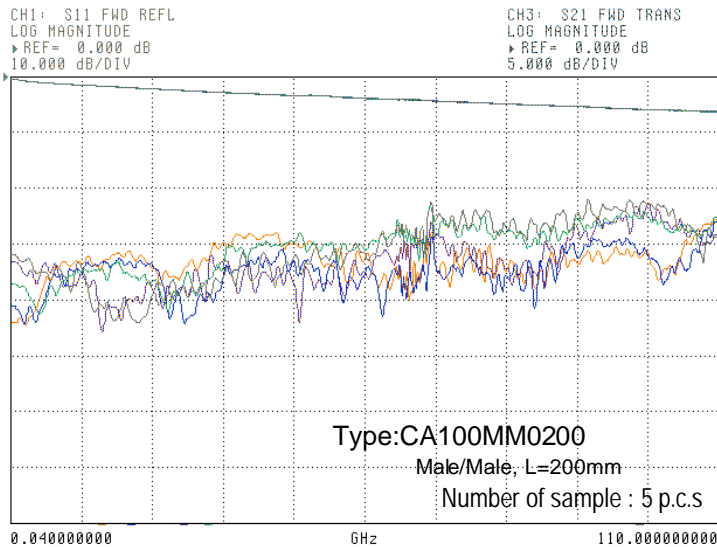
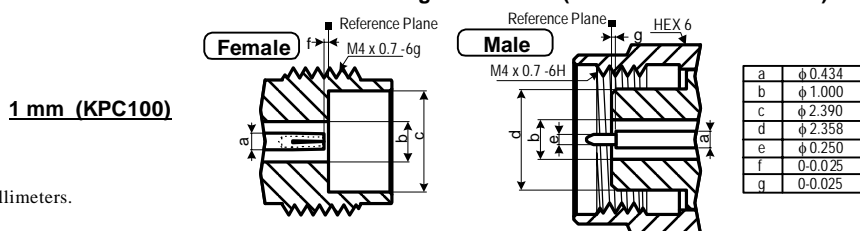

Fig.2 Typical performance

Cable Properties:

- Outer Conductor: 1.19 mm Dia.Copper with Cu/Sn/Zn plated
- Center Conductor: Silver plated copper
- Insulator: PTFE
- Moding Freq: 112GHz(Approx.)
- Delay Time:0.476ns/100mm
- Inside Bending Radius: 3 mm(min)
- Non-Magnetic

Connector Interface Mating Dimensions (IEEE-std-287 Conformed)



Note:
All dimensions are in Millimeters.

Specifications Subject to Change Without Notice.

Copyright(C) 2006KAWASHIMA Mfg. Co., Ltd. All rights reserved.

CA100FF/MF/MM Rev.01 Nov. 30 2006



Kawashima Manufacturing Co., Ltd.

1-3-5 Higashiikuta, Tama-ku,
Kawasaki 214-0031 JAPAN

TEL: +81-44-911-7073 FAX: +81-44-911-9621
http://www.kmco.biz/ e-mail: sales@ kmco.co.jp

Re-Formable Semirigid Cable Assemblies:

Connector Interface 1.85mm for DC - 65GHz and DC - 60GHz, 2.4mm for DC - 50GHz, 2.92mm for DC - 40GHz

DESCRIPTION The Re-Formable Semirigid Cable Assemblies, up to 40, 50, 60 and 65 GHz, easy to install with bending on your Labs./Sites, are designed for broadband measurement, instrument and system use. All materials are "lead free".

SPECIFICATIONS:

Insertion Loss : See Fig.1
 Temperature Range : -55 to 100 deg.C
 Length (L) : 35 to 300mm +/-2mm [**](5mm/step)-----Standard
 (Over 300mm to 1500mm, Considerable)

[*] Non Interconnect

[**] Please specify length(L: see following table), when you order this item.

For example: CA185MM0035 (Length:35mm)

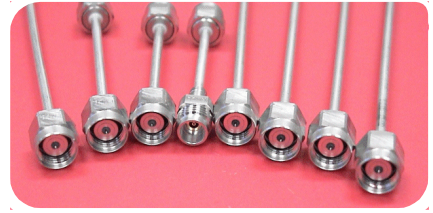

Production Status
 Two weeks Lead-Time will be available for shipping.

TYPE	Frequency Range	Return Loss	Connector Interfaces	Insertion Loss	Cable Properties
CA185FF LD Female/Female	DC-65GHz	Better than 17 dB	1.85mm	See Curve "A" in Fig.1	=Curve "A" in Fig.1= Outer Conductor: 2.2mm Dia. Copper with Cu/Sn/Zn plated Center Conductor: Silver plated copper clad steel Insulator: Low density PTFE Moding Freq.: 70GHz(Approx.) Delay Time: 1.27ns/300mm Inside Bending Radius: 7mm(min)
CA185MF LD Male/Female					
CA185MM LD Male/Male					
CA185FF Female/Female	DC-60GHz	Better than 18 dB	1.85mm	See Curve "B" in Fig.1	=Curve "B" in Fig.1= Outer Conductor: 2.2mm Dia. Copper with Cu/Sn/Zn plated Center Conductor: Silver plated copper Insulator: Solid PTFE Moding Freq.: 61GHz(Approx.) Delay Time: 1.43ns/300mm Inside Bending Radius: 3.2mm(min) Non-Magnetic
CA185MF Male/Female					
CA185MM Male/Male					
CA185- [*] Male/Male	DC-50GHz	Better than 20 dB	2.4mm	See Curve "B" in Fig.1	=Curve "B" in Fig.1= Outer Conductor: 2.2mm Dia. Copper with Cu/Sn/Zn plated Center Conductor: Silver plated copper Insulator: Solid PTFE Moding Freq.: 61GHz(Approx.) Delay Time: 1.43ns/300mm Inside Bending Radius: 3.2mm(min) Non-Magnetic
CA240FF Female/Female					
CA240MF Male/Female					
CA240MM Male/Male	DC-40GHz	Better than 20 dB	2.92mm	See Curve "B" in Fig.1	=Curve "B" in Fig.1= Outer Conductor: 2.2mm Dia. Copper with Cu/Sn/Zn plated Center Conductor: Silver plated copper Insulator: Solid PTFE Moding Freq.: 61GHz(Approx.) Delay Time: 1.43ns/300mm Inside Bending Radius: 3.2mm(min) Non-Magnetic
CA292FF Female/Female					
CA292MF Male/Female					
CA292MM Male/Male					

Reference for minimum cable installation space with rounded Re-Forming

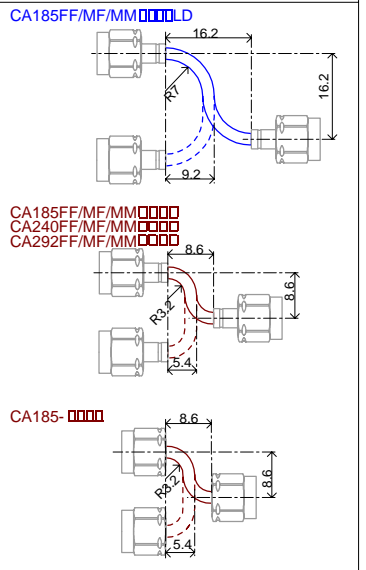

Hand Bender 2200 For Re-Forming(R3.2/7mm)



Notice:
 About the cable bending with hand bender 2200
 To prevent the cable damage in the joint part of the cable and the connector, Please bend the cable in a place about 4mm away from the joint part.

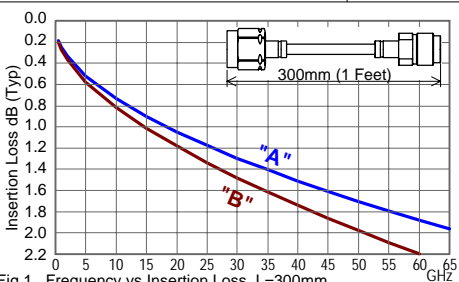
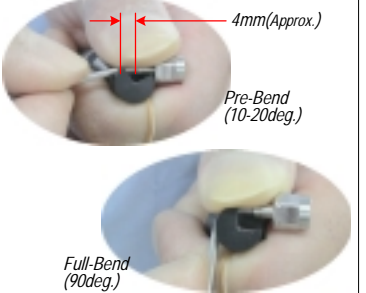

Fig.1 Frequency vs Insertion Loss, L=300mm

When you install the cable assemblies, please support a cable near the connector and tighten the nut, because the cable that composed of a thin copper tube may be damaged easily by a twist stress.



Fig.2 Tightening of Nut

Connector Interface Mating Dimensions (IEEE-std-287 Conformed)

1.85mm (KPC185)

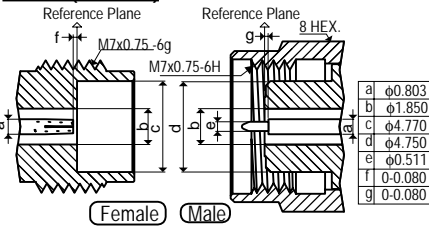

2.4mm (KPC240)

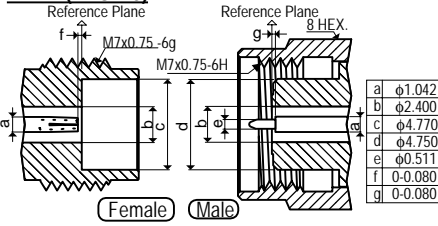

2.92mm (KPC292)

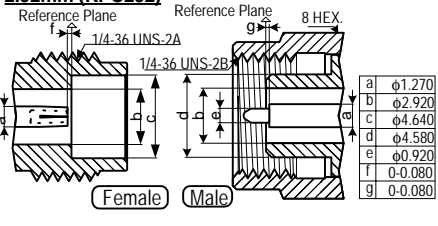

Specifications Subject to Change Without Notice.

Note: All dimensions are in Millimeters.

CA185_240_292 Rev.02 Aug. 31 2004

Copyright(C) 2004 KAWASHIMA Mfg. Co., Ltd. All rights reserved.



Kawashima Manufacturing Co., Ltd.

1-3-5 Higashiikuta, Tama-ku, Kawasaki 214-0031 JAPAN

TEL: +81-44-911-7073 FAX: +81-44-911-9621
 http://www.kmco.biz/ e-mail: sales@kmco.co.jp

Re-Formable Semirigid Cable Assemblies, Between: Connector Interface 2.4mm/1.85mm for DC - 50GHz and 2.92mm/1.85mm, 2.92mm/2.4mm for DC - 40GHz

DESCRIPTION The Re-Formable Semirigid Cable Assemblies, Between, up to 40 and 50 GHz, **easy to install with bending** on your Labs./Sites, are designed for broadband measurement, instrument and system use. All materials are **lead free**".

SPECIFICATIONS:

- Insertion Loss : See Fig.1
- Return Loss : Better than 18dB
- Temperature Range : -55 to 100 deg.C
- Length (L) : 35 to 300mm +/-2mm [*](5mm/step)-----Standard
(Over 300mm to 1500mm, Considerable)



Production Status
Two weeks Lead-Time will be available for shipping.

[*] Please specify length(L: □□□□ see following table), when you order this item.
For example: CA240F185M0035 (Length:35mm)

TYPE	Connector Interfaces	Frequency Range	Cable Properties	Reference for minimum cable installation space with rounded Re-Forming
CA240F185F □□□□ 2.4mm Female/1.85mm Female	2.4mm and 1.85mm	DC-50GHz	Outer Conductor: 2.2mm Dia.Copper with Cu/Sn/Zn plated	
CA240F185M □□□□ 2.4mm Female/1.85mm Male				
CA240M185F □□□□ 2.4mm Male/1.85mm Female				
CA240M185M □□□□ 2.4mm Male/1.85mm Male				
CA292F185F □□□□ 2.92mm Female/1.85mm Female	2.92mm and 1.85mm	DC-40GHz	Center Conductor: Silver plated copper	<p>Insulator: Solid PTFE</p> <p>Moding Freq.: 61GHz(Approx.)</p> <p>Delay Time: 1.43ns/300mm</p> <p>Inside Bending Radius: 3.2mm(min)</p> <p>Non-Magnetic</p>
CA292F185M □□□□ 2.92mm Female/1.85mm Male				
CA292M185F □□□□ 2.92mm Male/1.85mm Female				
CA292M185M □□□□ 2.92mm Male/1.85mm Male				
CA292F240F □□□□ 2.92mm Female/2.4mm Female	2.92mm and 2.4mm			<p>Hand Bender 2200 For Re-Forming(R3.2/7mm)</p> <p>Notice: About the cable bending with hand bender 2200 To prevent the cable damage in the joint part of the cable and the connector, Please bend the cable in a place about 4mm away from the joint part.</p>
CA292F240M □□□□ 2.92mm Female/2.4mm Male				
CA292M240F □□□□ 2.92mm Male/2.4mm Female				
CA292M240M □□□□ 2.92mm Male/2.4mm Male				

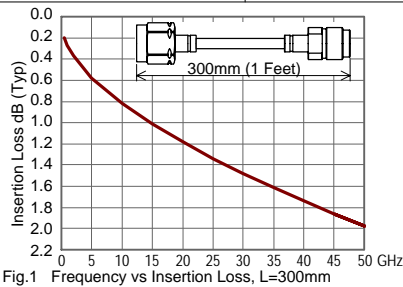

When you install the cable assemblies, please support a cable near the connector and tighten the nut, because the cable that composed of a thin copper tube may be damaged easily by a twist stress.



Connector Interface Mating Dimensions (IEEE-std-287 Conformed)

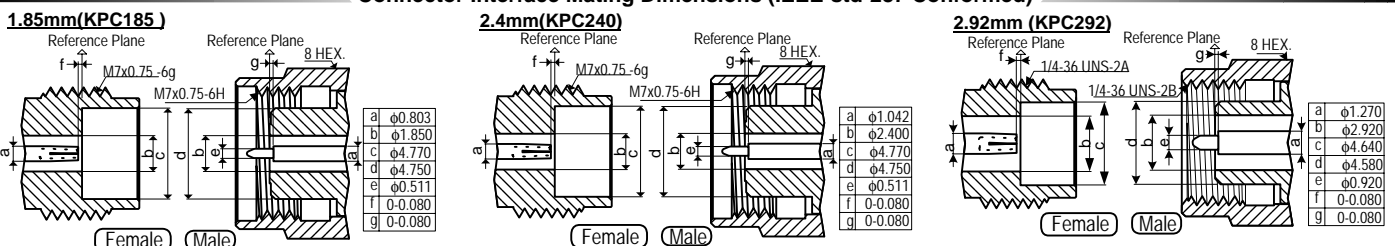

Specifications Subject to Change Without Notice.

Note: All dimensions are in Millimeters.

CA185_240_292 Between, Rev.00 Sep. 24 2004

Copyright(C) 2004 KAWASHIMA Mfg. Co., Ltd. All rights reserved.



Kawashima Manufacturing Co., Ltd.

1-35 Higashiikuta, Tama-ku,
Kawasaki 214-0031 JAPAN

TEL: +81-44-911-7073 FAX: +81-44-911-9621
http://www.kmco.biz/ e-mail: sales@kmco.co.jp